

*FAPESP Advanced School on Atmospheric
Aerosols IFUSP – August 1, 2019*



Secondary Organic Aerosols formation in Amazonia and urban areas

Paulo Artaxo

University of Sao Paulo, Brazil

Secondary Organic Aerosols (SOAs)

Aerosols are produced from the atmospheric oxidation of volatile organic compounds (VOCs), which are emitted by plants, household products, and combustion of hydrocarbons.

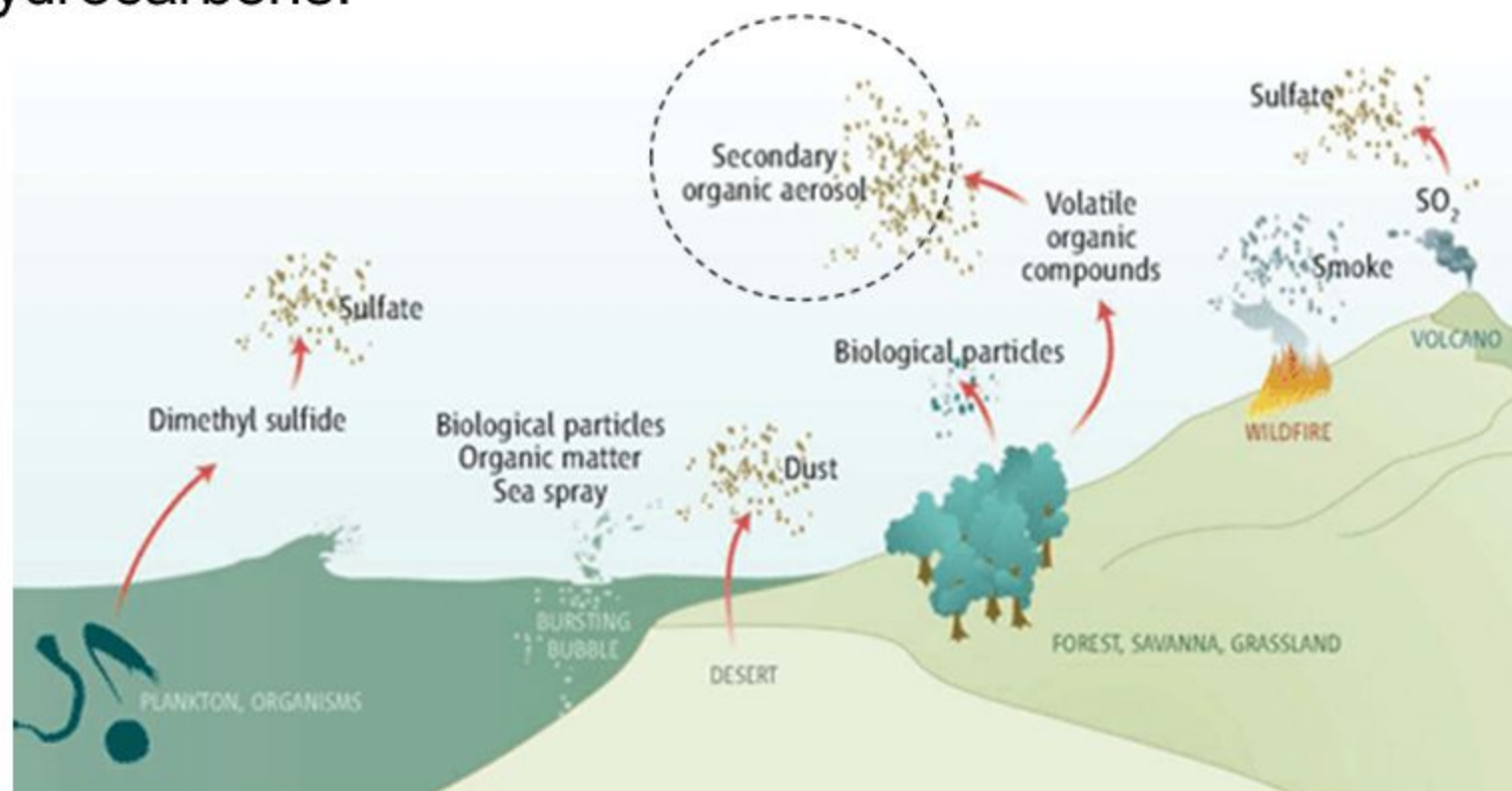

Fungal spores as a source of sodium salt particles in the Amazon basin

Swarup China¹, Susannah M. Burrows², Bingbing Wang³, Tristan H. Harder^{4,5,11}, Johannes Weis^{4,5,11}, Meryem Tanarhte⁶, Luciana V. Rizzo⁷, Joel Brito^{8,12}, Glauber G. Cirino⁹, Po-Lun Ma², John Cliff¹, Paulo Artaxo⁸, Mary K. Gilles⁴ & Alexander Laskin¹⁰

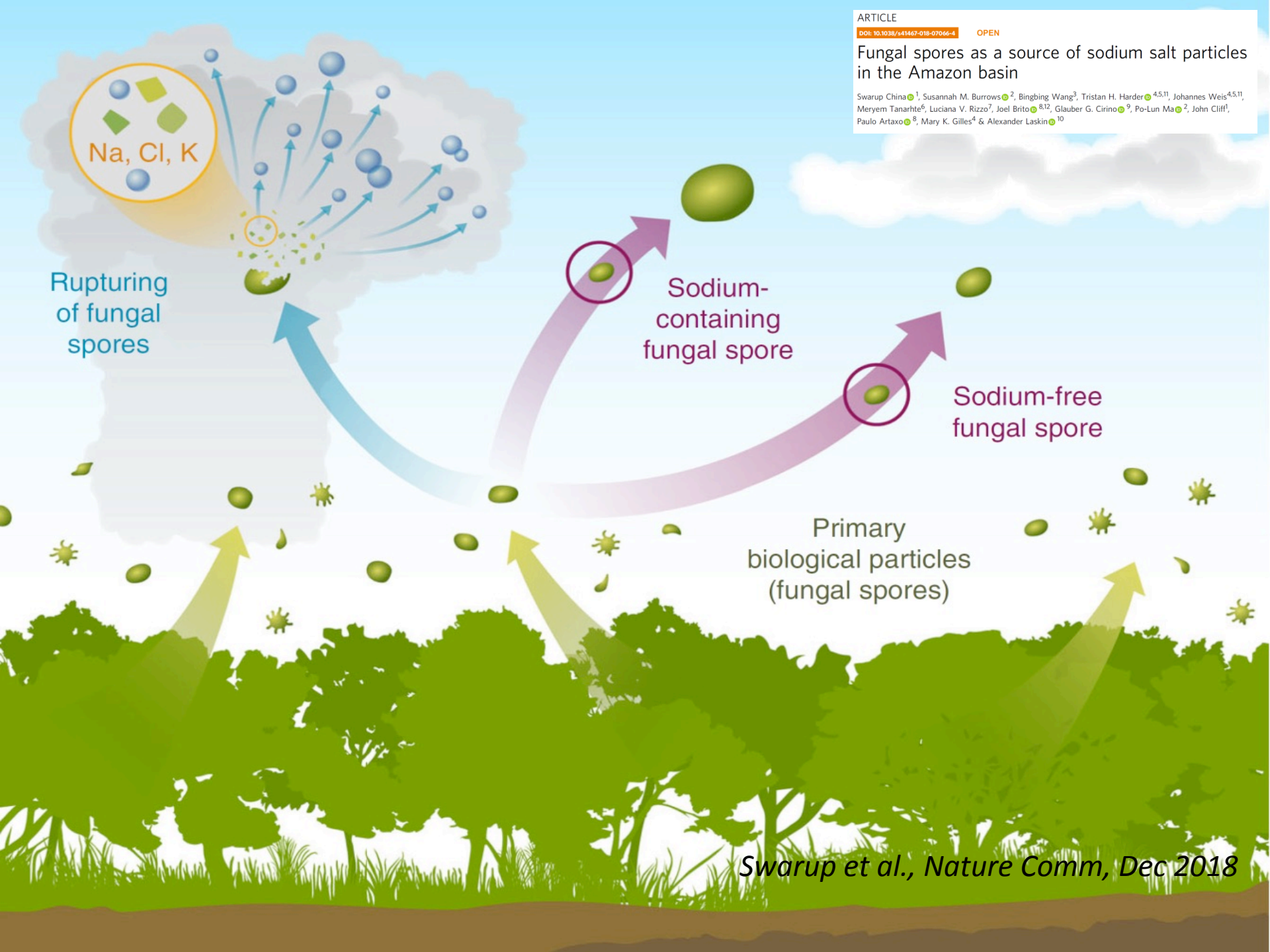

SOA aerosols and Clouds life cycles with ecosystem impacts

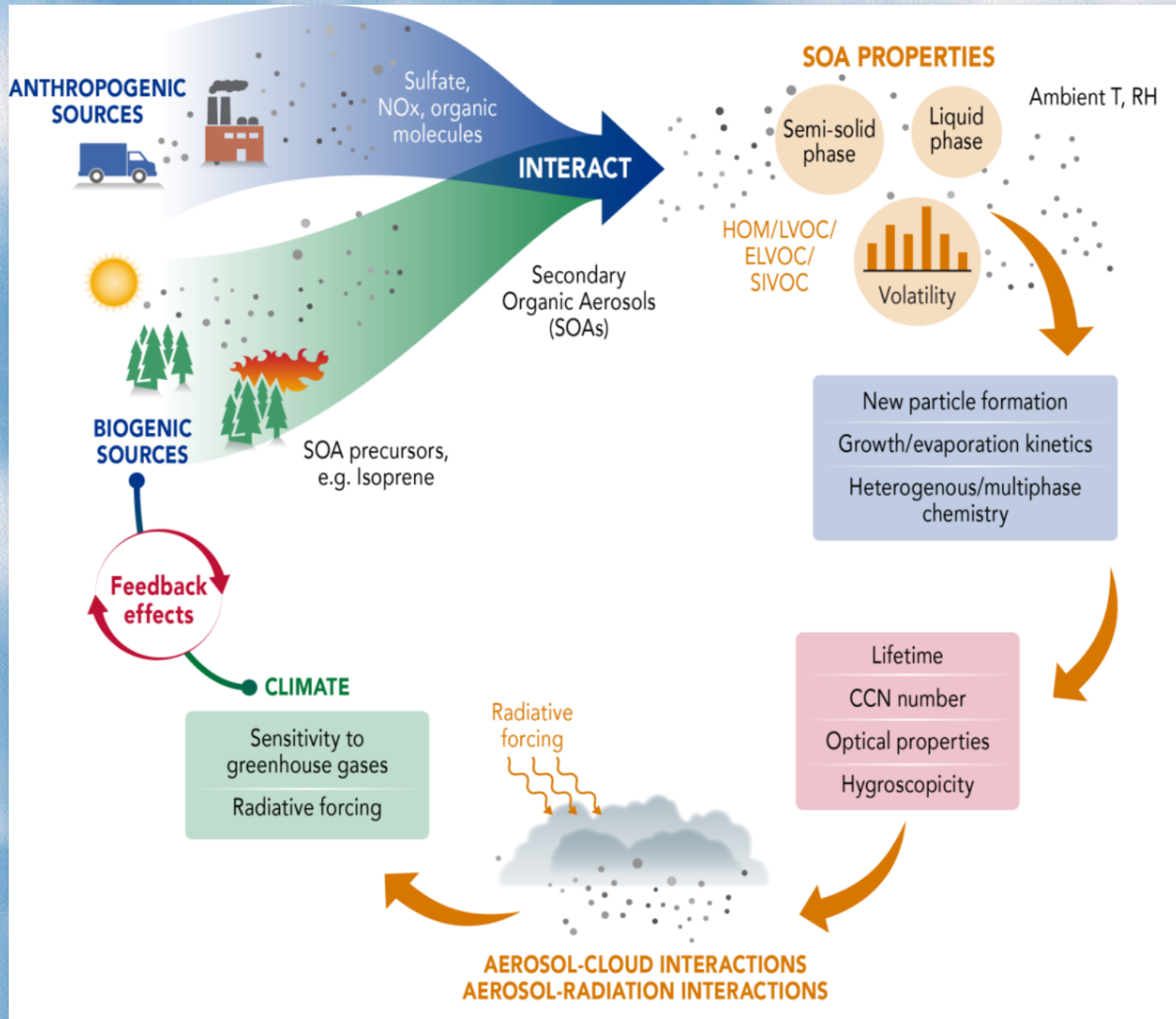

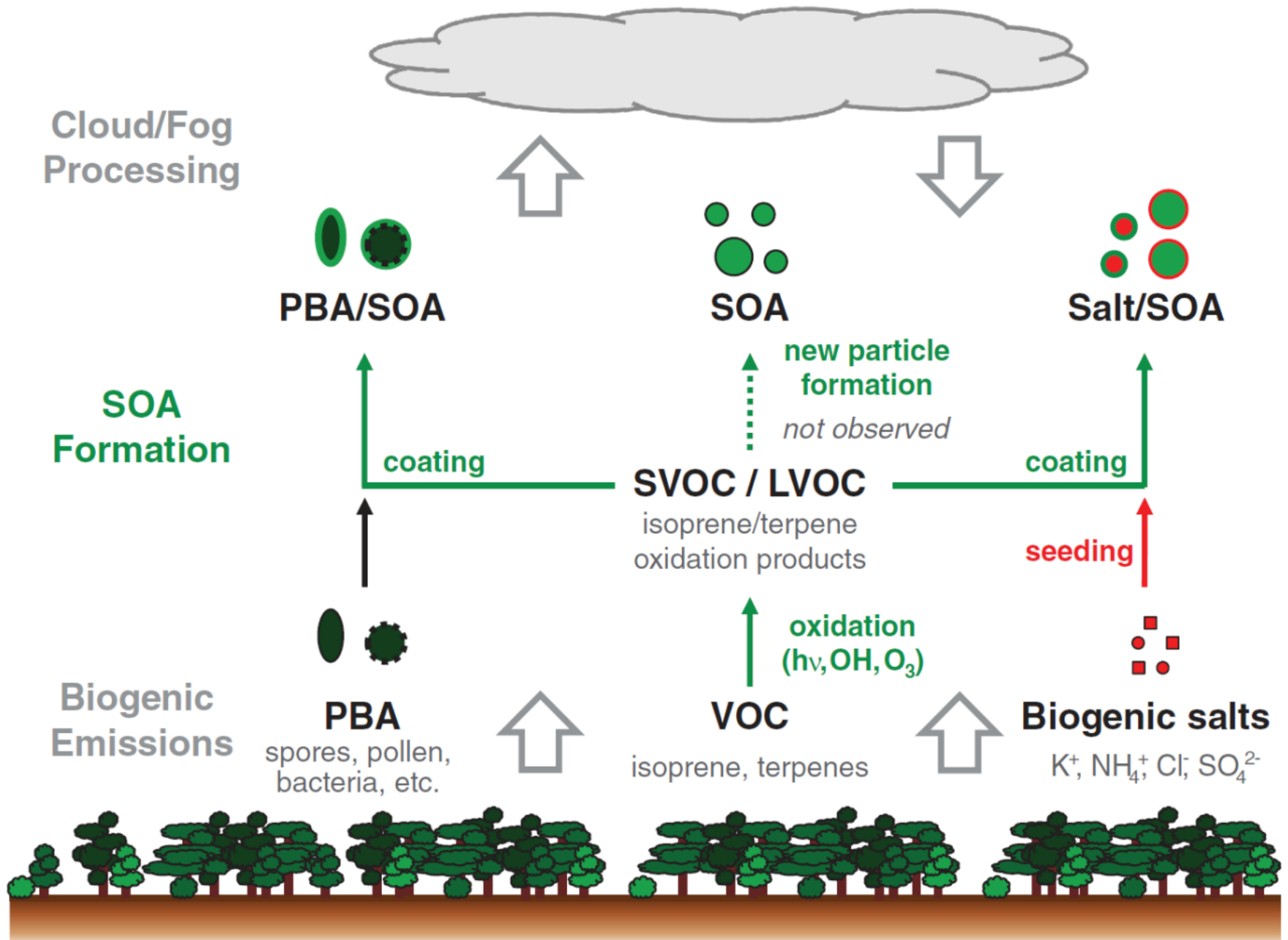

isoprene epoxydiols (IEPOX) and SOA

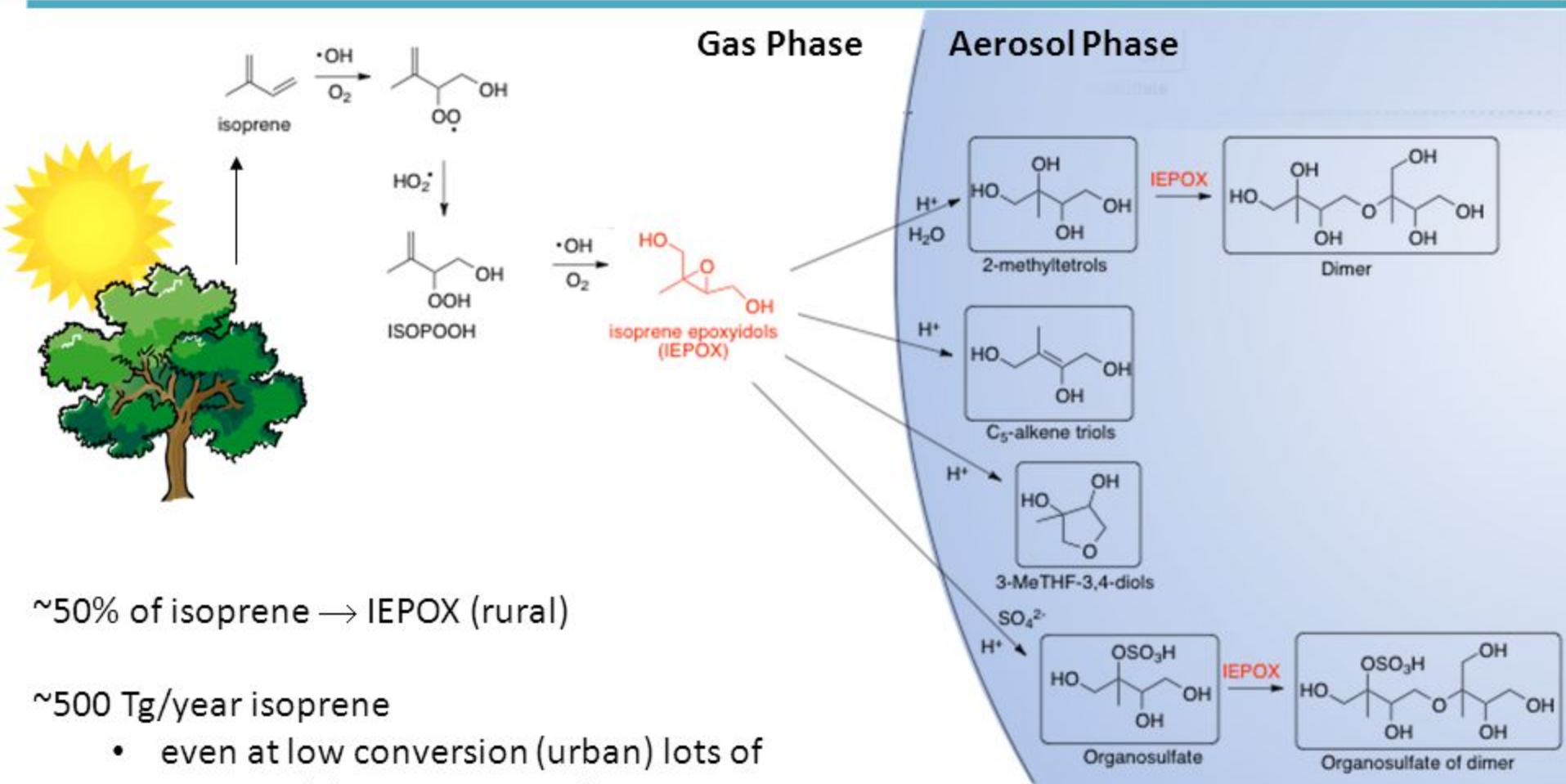

~50% of isoprene \rightarrow IEPOX (rural)

~500 Tg/year isoprene

- even at low conversion (urban) lots of potential mass to aerosols

“tracers” \equiv aerosol products from IEPOX that contribute to SOA mass

Atmospheric importance of isoprene

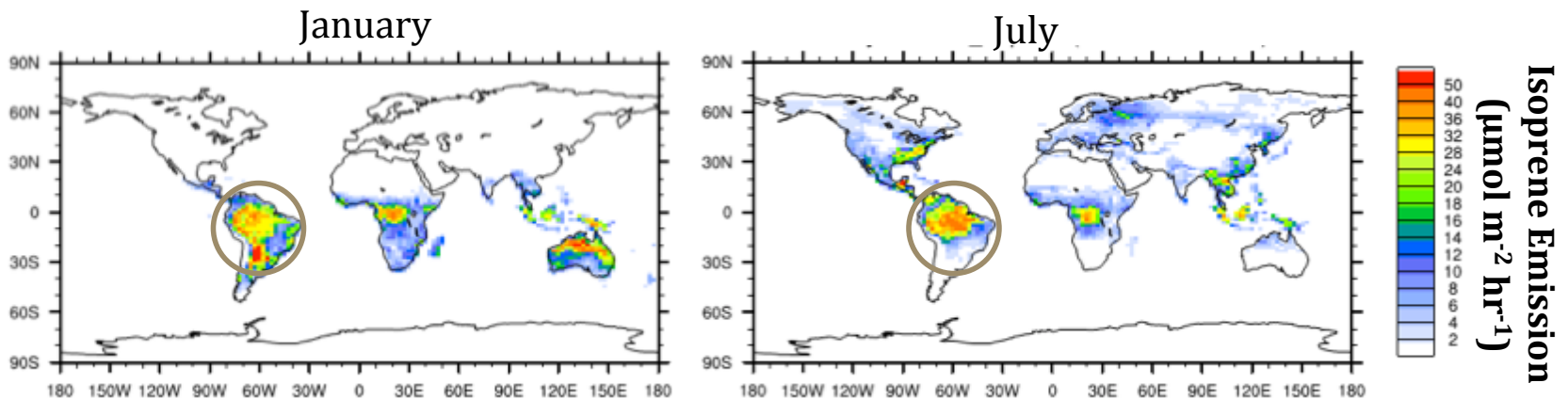
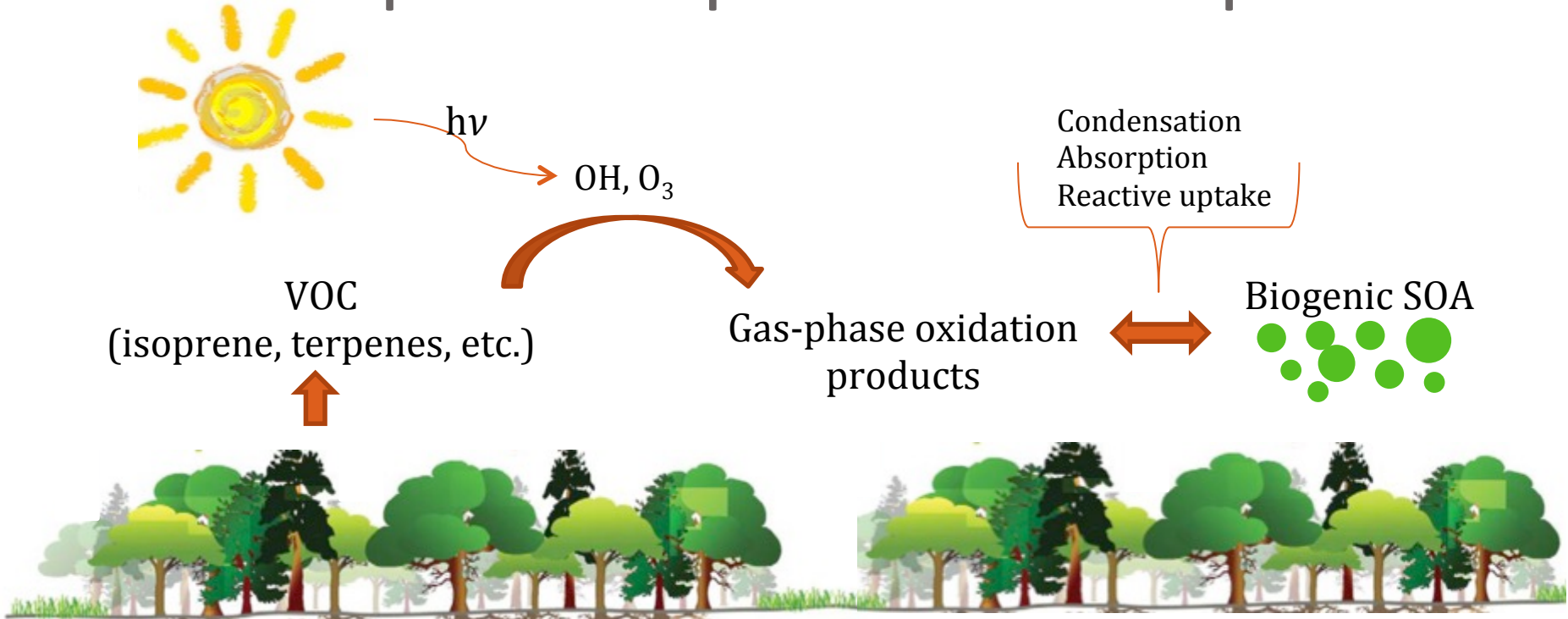

(Adapted from Guenther et al., 2012)

Evolution of Organic Aerosols in the Atmosphere

J. L. Jimenez,^{1*} M. R. Canagaratna,² N. M. Donahue,³ A. S. H. Prevot,^{4*} Q. Zhang,^{5,6} J. H. Kroll,^{2,7} P. F. DeCarlo,^{1,4,8} J. D. Allan,^{9,10} H. Coe,⁹ N. L. Ng,² A. C. Aiken,^{1†} K. S. Docherty,¹ I. M. Ulbrich,¹ A. P. Grieshop,^{3‡} A. L. Robinson,³ J. Duplissy,^{4§} J. D. Smith,¹¹ K. R. Wilson,¹¹ V. A. Lanz,^{4,12} C. Huebner,¹² V. I. Sui,^{5,6} T. Timp,⁵ A. Lopez,^{13,14} T. B. Onipinla,^{13,14} T. B. Onipinla,¹³

Aerosols:

- 1) Primary (Dust, sea salt, primary industry)
- 2) Secondary (SO₄, NO₃)
- 3) Secondary Organic Aerosols (SOA)

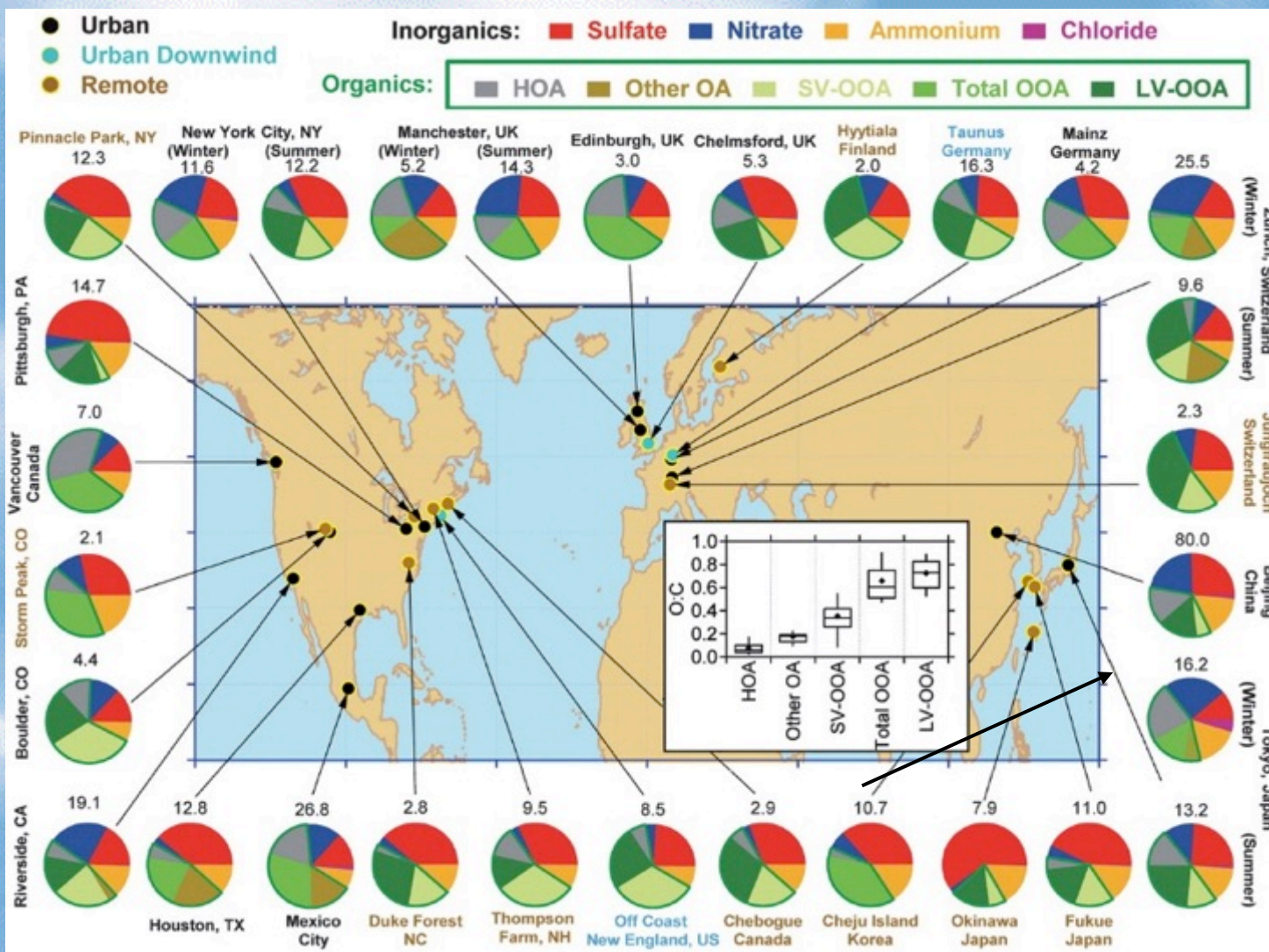

World without Southern Hemisphere?

Atmospheric importance of IEPOX-SOA

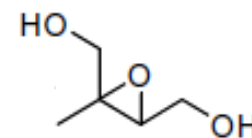

IEPOX

IEPOX-SOA = SOA derived from isoprene epoxydiols (IEPOX):

IEPOX-SOA factor: estimated from positive matrix factorization (PMF) of AMS organic mass spectra

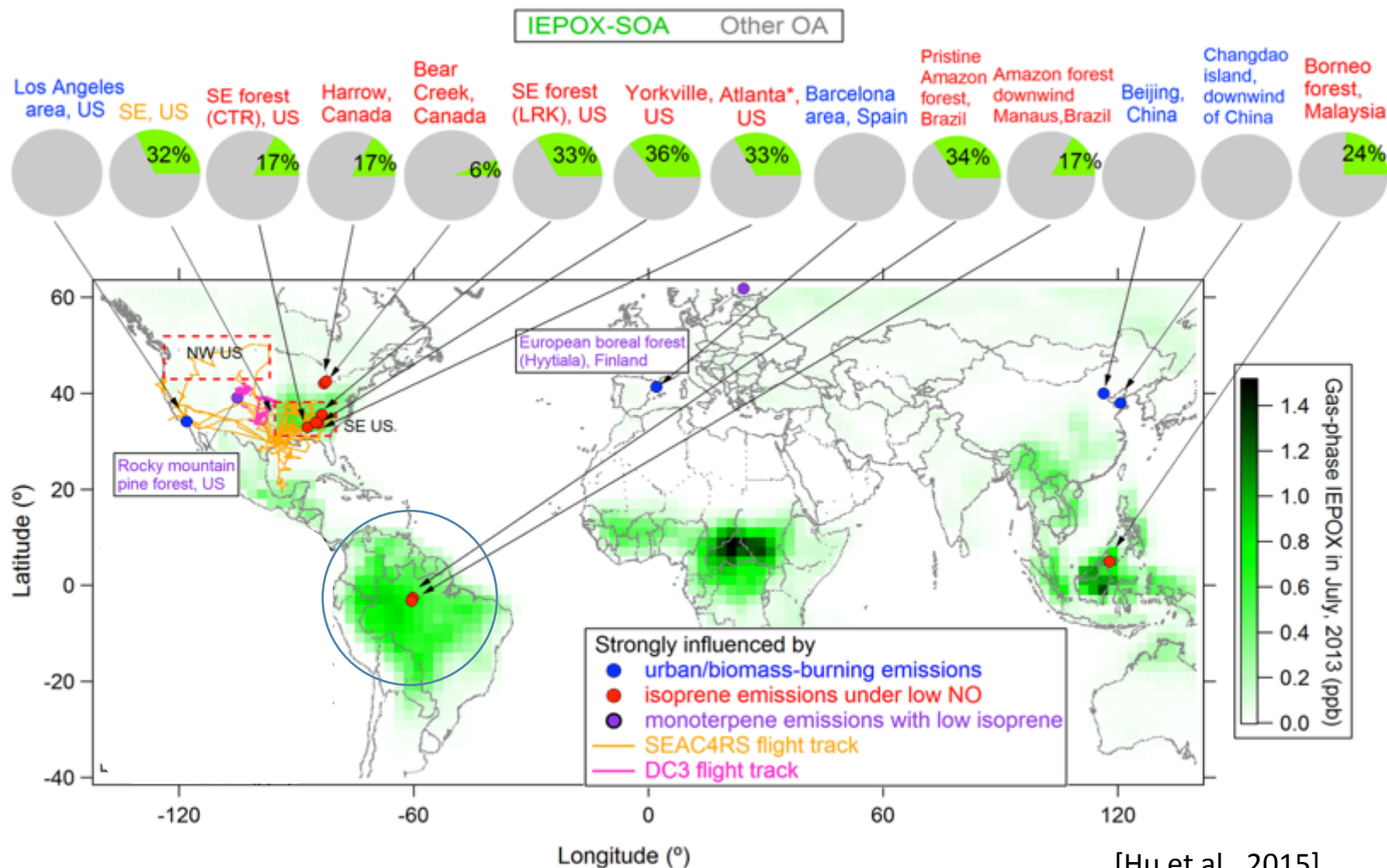

Total Global SOA Emissions Range

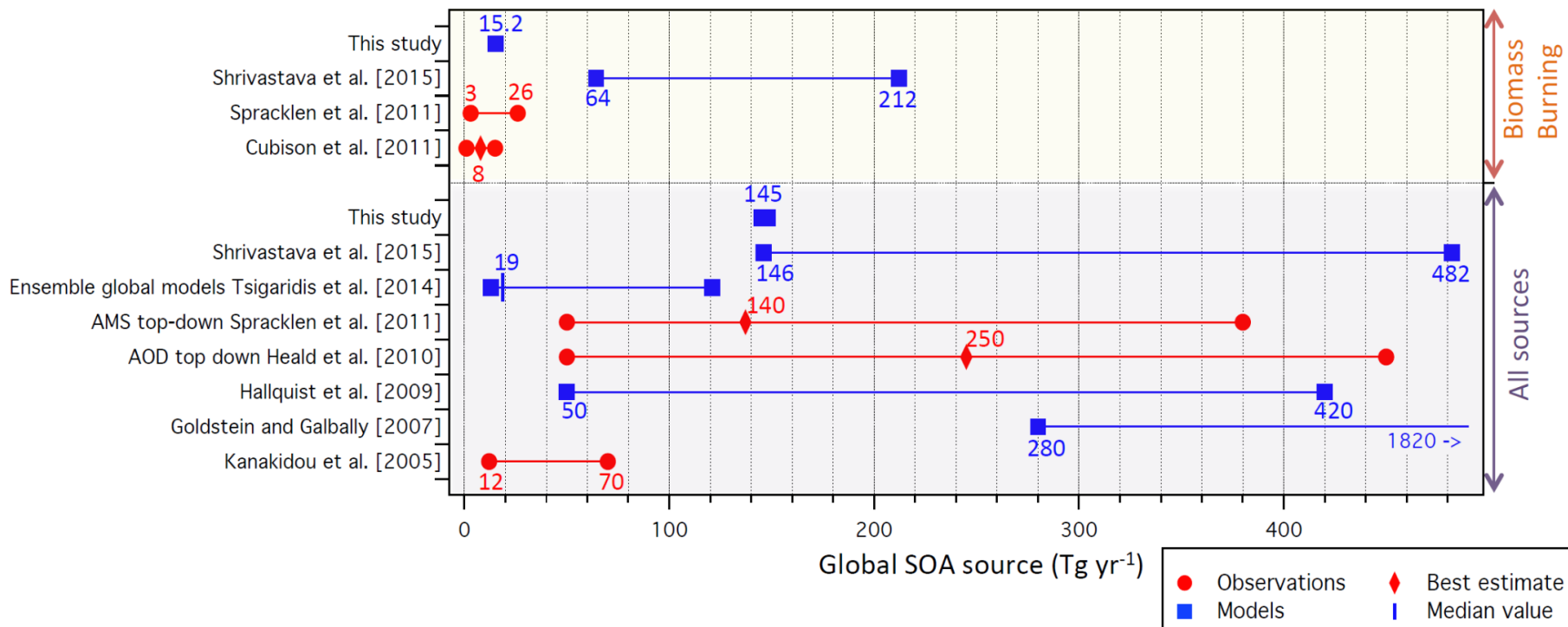

Hodzic *et al.* (2016)

- Total emission range of global SOA: 10 to 500 Tg/year;
- Degree of ABSURD uncertainty;
- Generally, from 60% to 80% of the total aerosol mass is SOA

SOA Modeling / Simulation of Profile Evolution

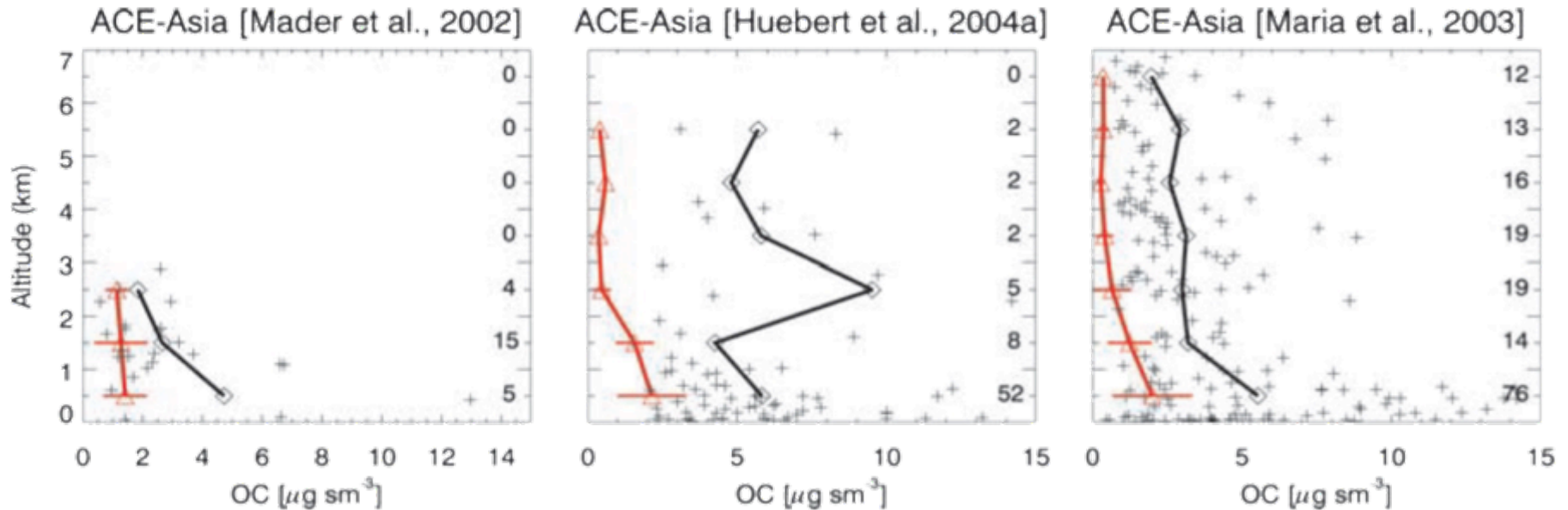

Heald *et al.* (2005)

- 15 years ago, SOA was basically unknown information; At that time there was no necessary instrumentation.
- Today in 2018, It is not explicitly included in all climate model;
- Even models like WRF-Chem do not include all SOA production mechanisms (urban or remote).

Química Atmosférica e Mudanças Climáticas

VOCs em fase gasosa: Ozônio

VOCs e produção de aerossóis secundários

Meia vida de metano controlada pelo radical OH⁻

Monóxido de carbono (CO): importante no balanço de carbono

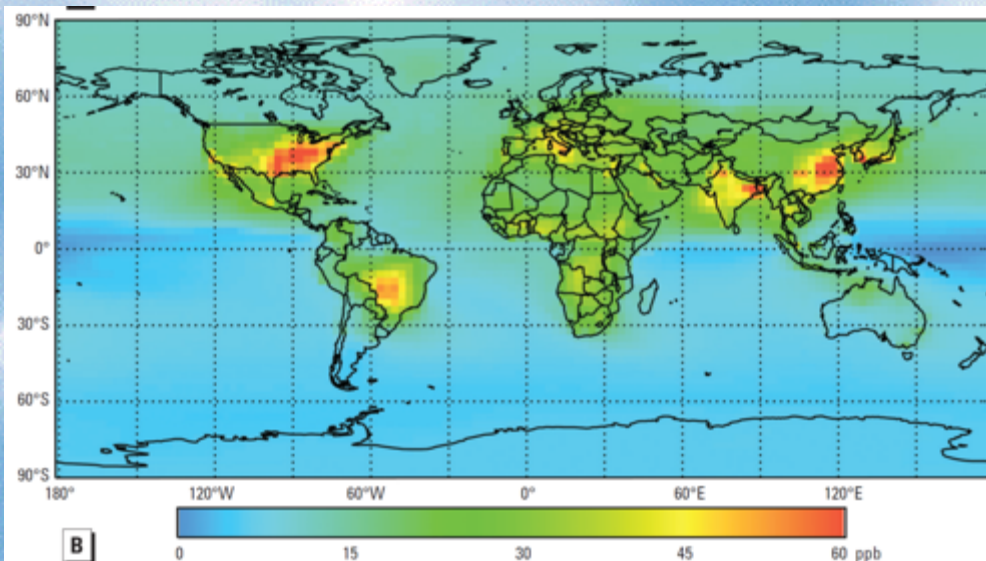

Aumento de ozônio (2010-1850) Máximo diário

a Gas phase reactions of VOCs

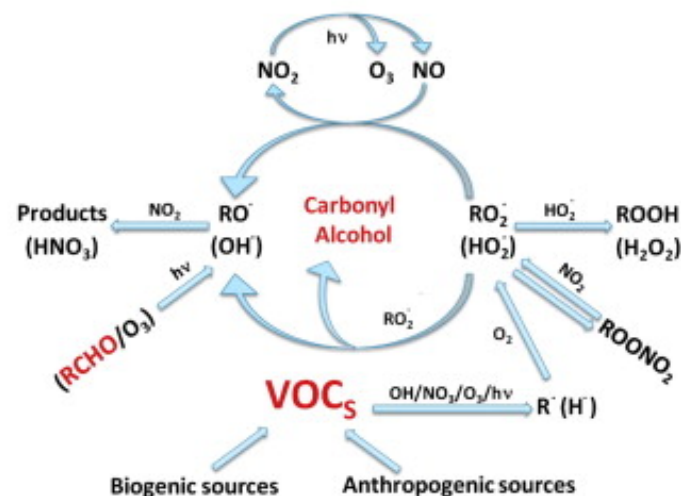

b Heterogeneous reactions of VOCs

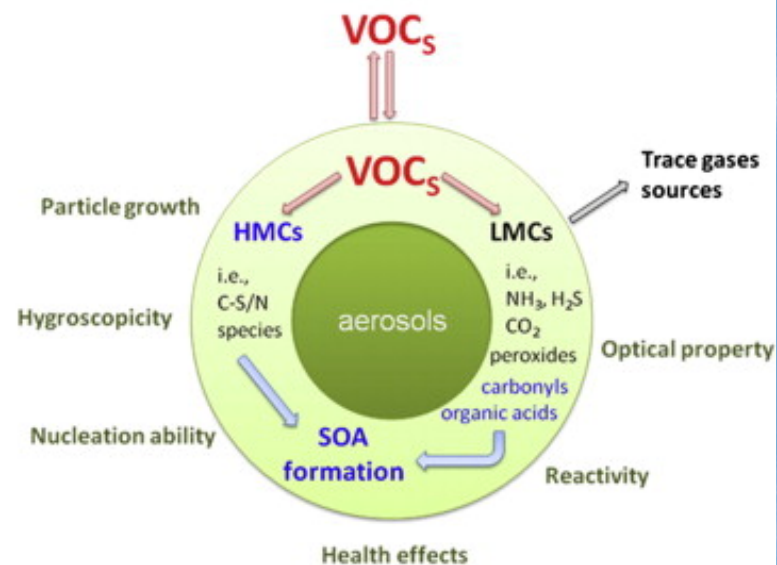

HMCs: high molecular weight compounds; LMCs: low molecular weight compounds

Production of IEPOX-derived PM from the photooxidation of isoprene

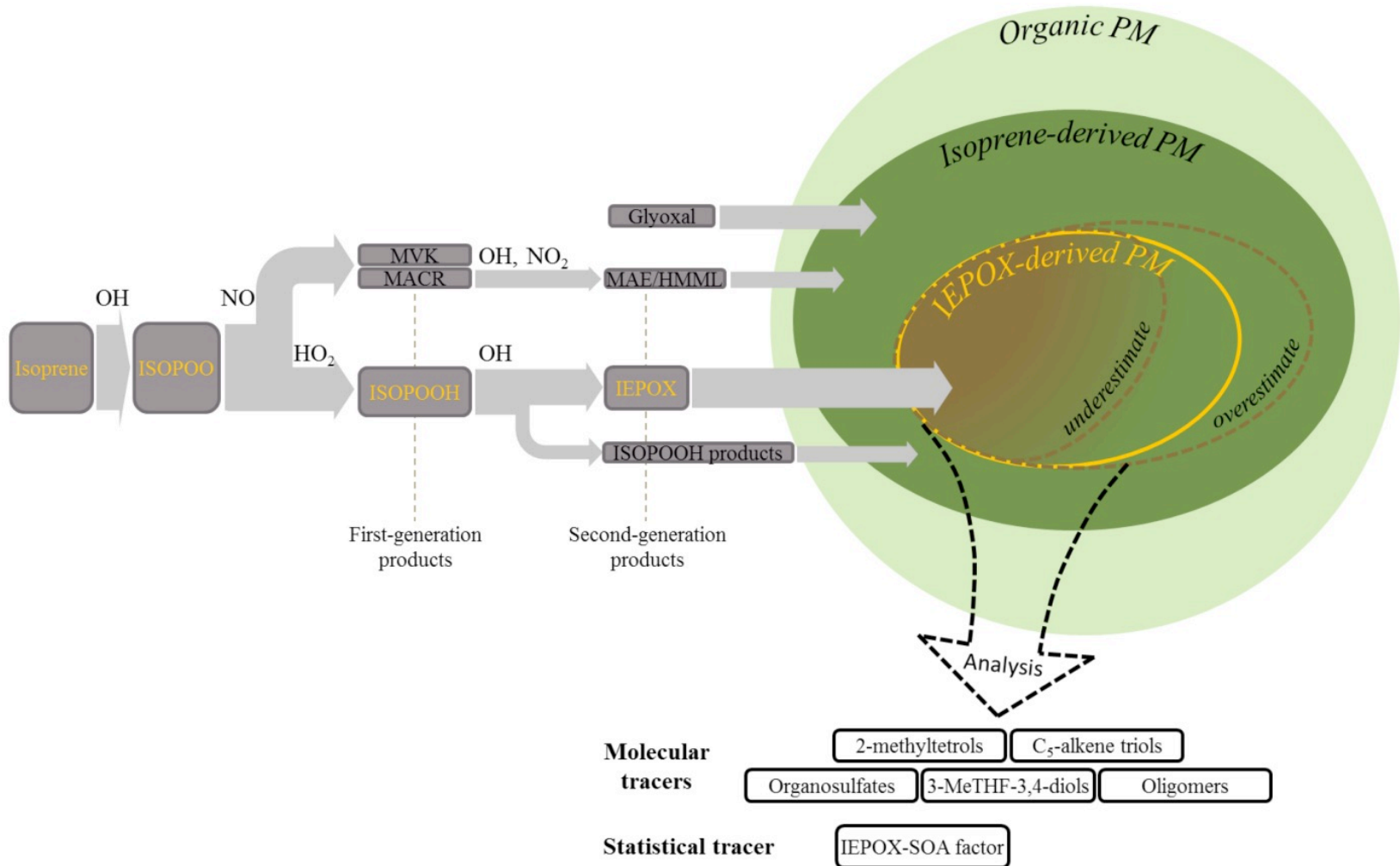

From VOCs, SOA, CCN to the canopy processes in Amazonia

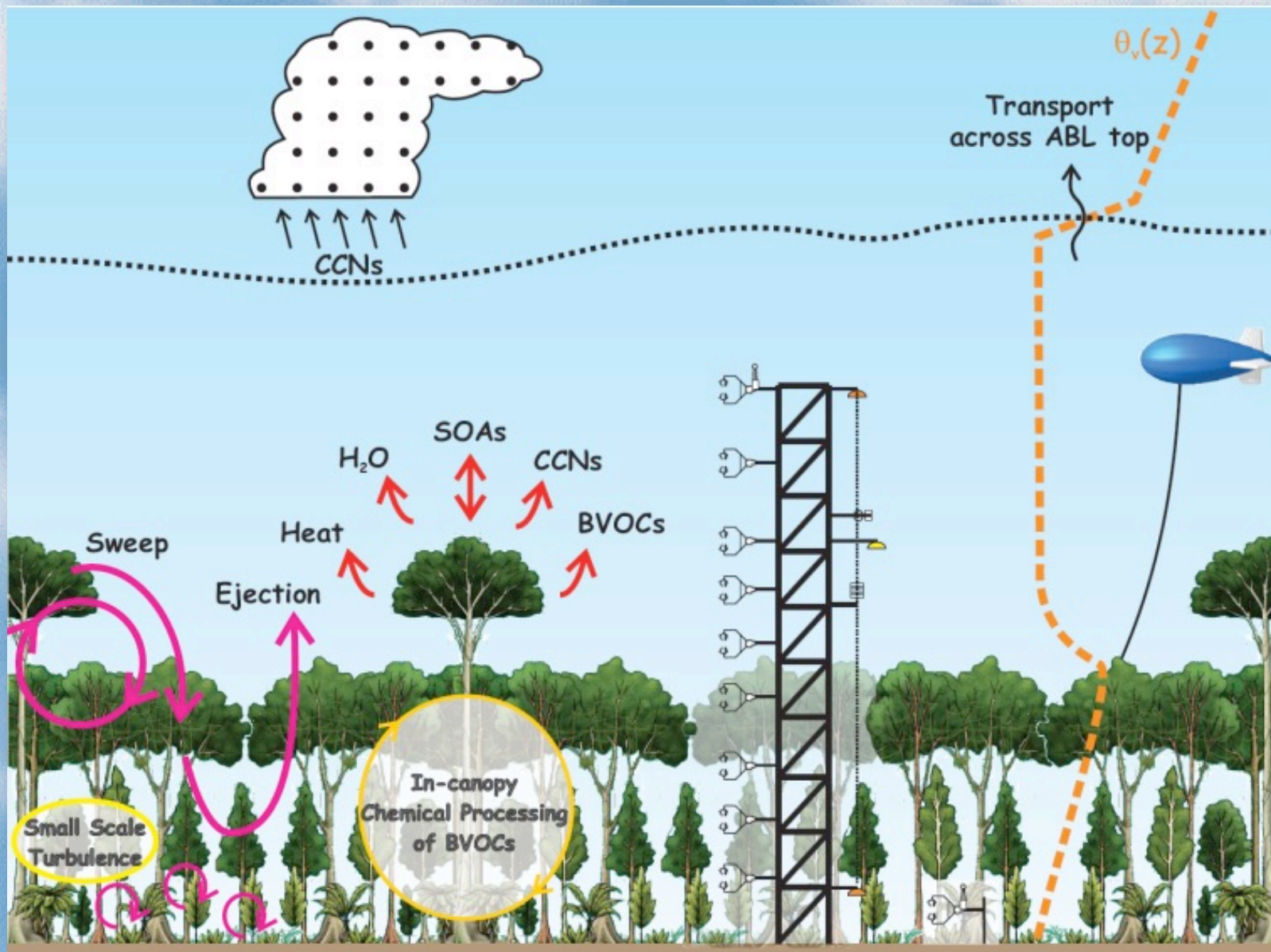

Air mass trajectories and footprint

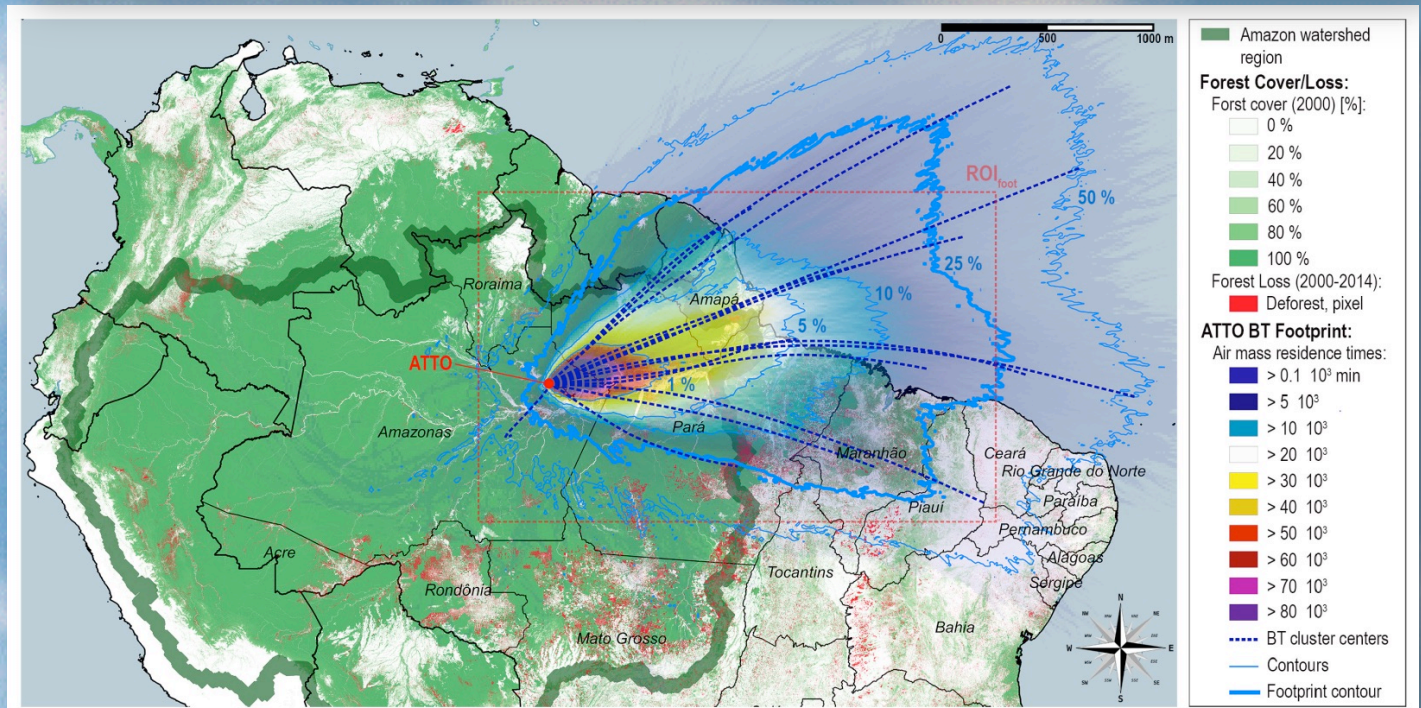
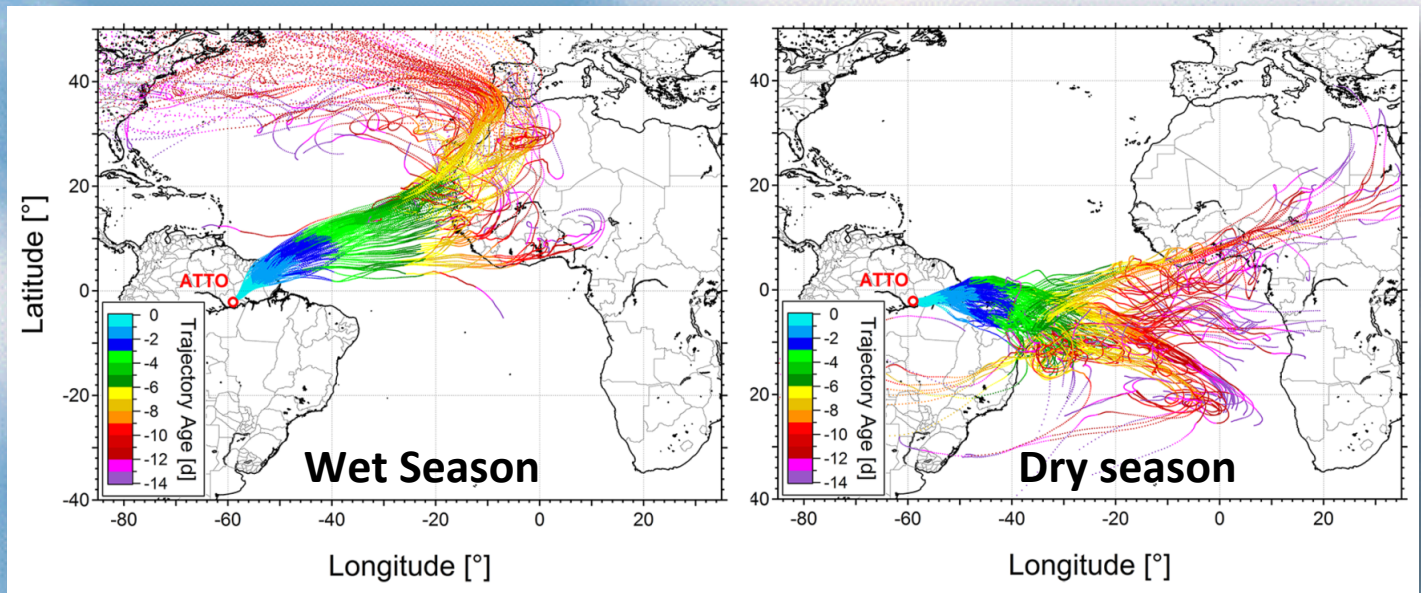

ATTO ACSM Monthly averages 2014-2016

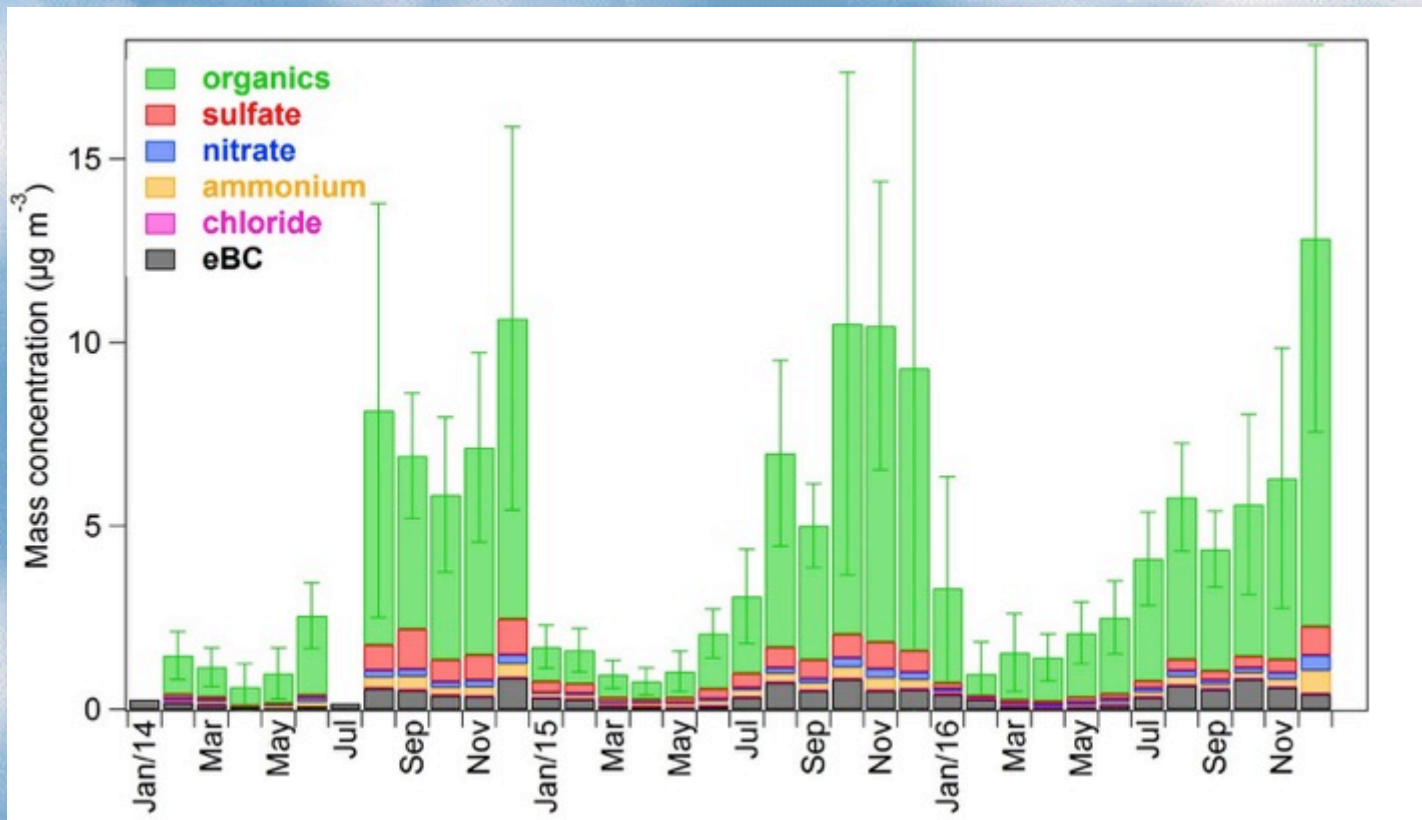

Most of the nitrates are organics

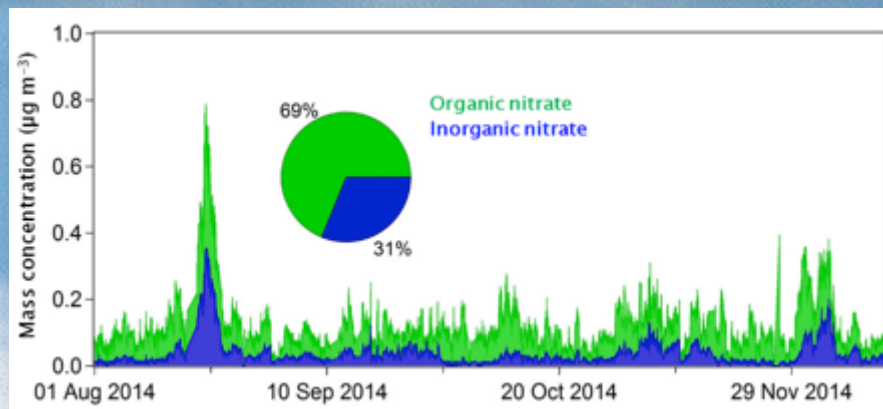

Organic aerosols from ATTO to Tiwa and Manacapuru (with BC)

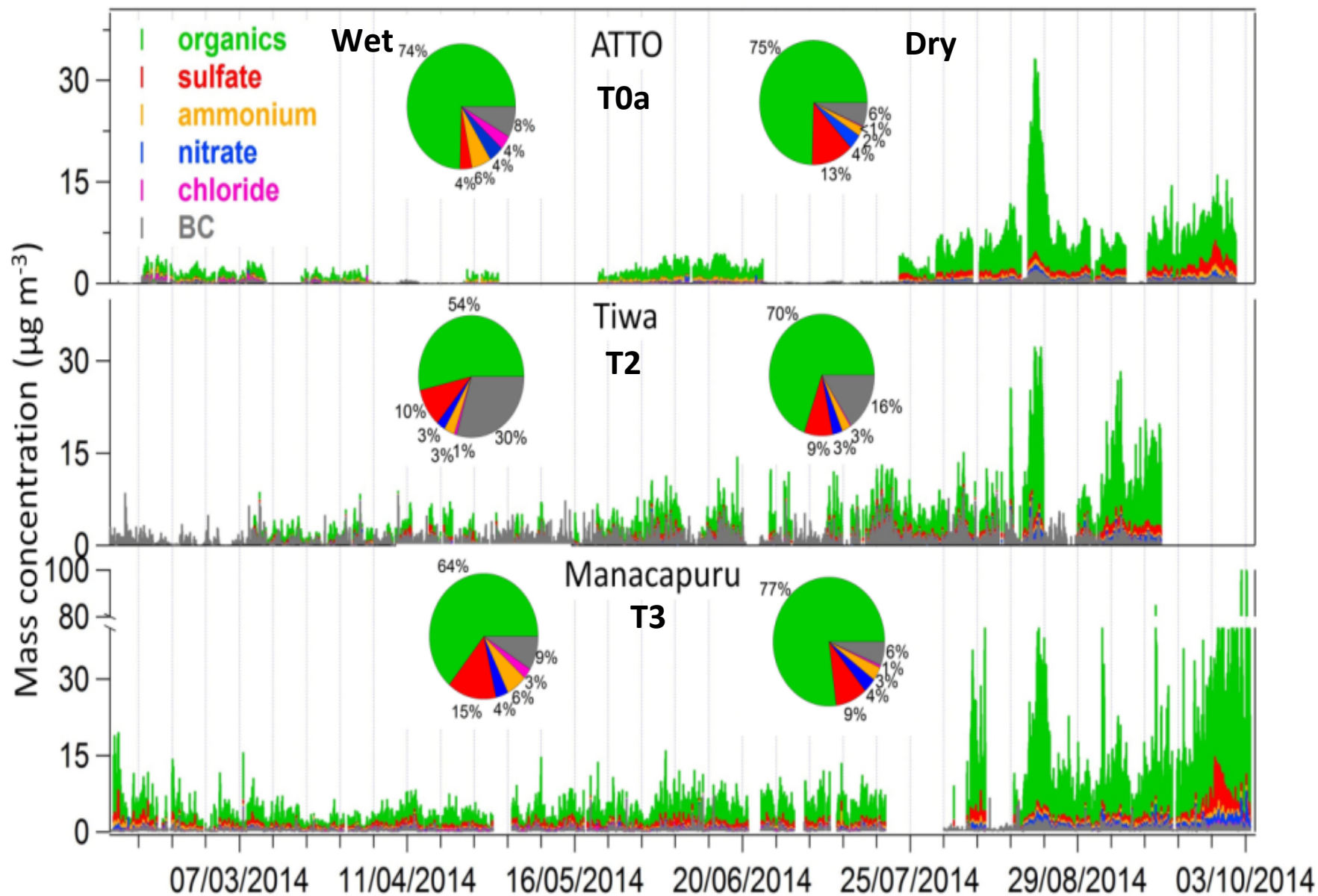

What drives light scattering and absorption for PM1?

T0a ATTO - Organics versus light scattering and absorption

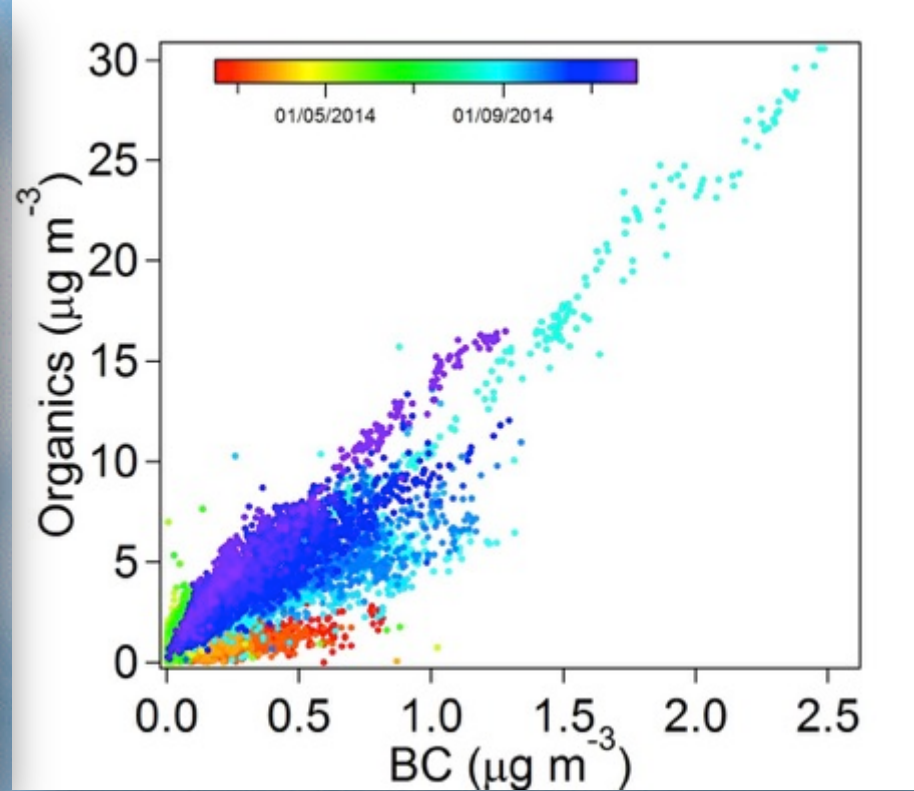
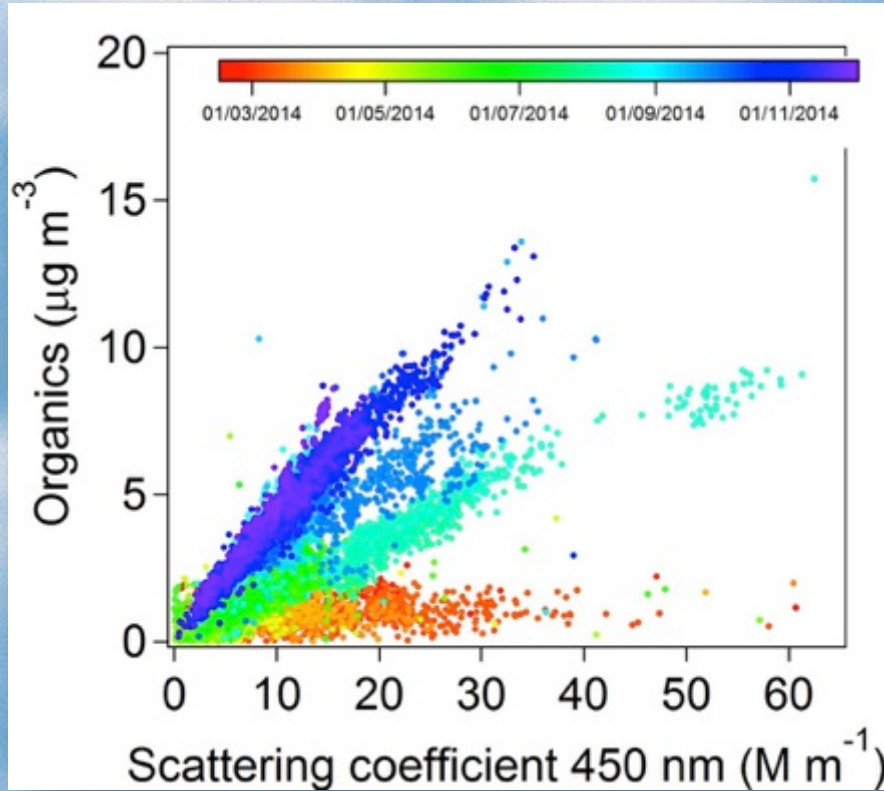

The organics made up to 76% of the fine particles and when investigated as a function of the scattering coefficient (σ_{450}) different patterns (with different slopes) were observed over time. BC also shows different patterns but less pronounced

The hygroscopicity parameter γ versus the organic mass fraction

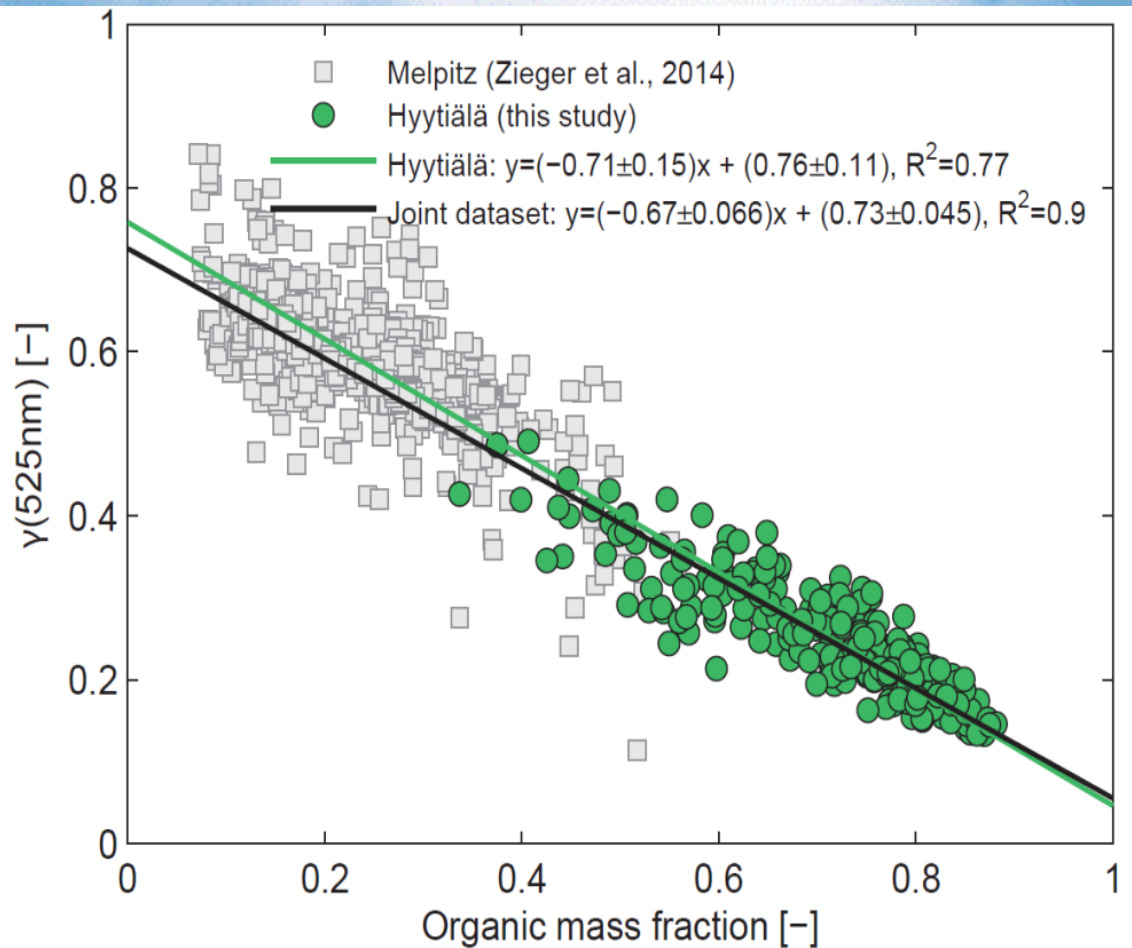

The hygroscopicity parameter γ the organic mass fraction for boreal aerosol measured in Hyytiälä, Finland (green points).

The grey show more inorganic dominated aerosol in Melpitz, Germany, during winter time.

γ describes the magnitude of the scattering of enhancement factor $f(\text{RH})$, where $f(\text{RH}) = \alpha(1 - \text{RH})^{-\gamma}$.

Zieger et al. (2015).

Optical properties versus aerosol aging – PVH, RBR, TT34

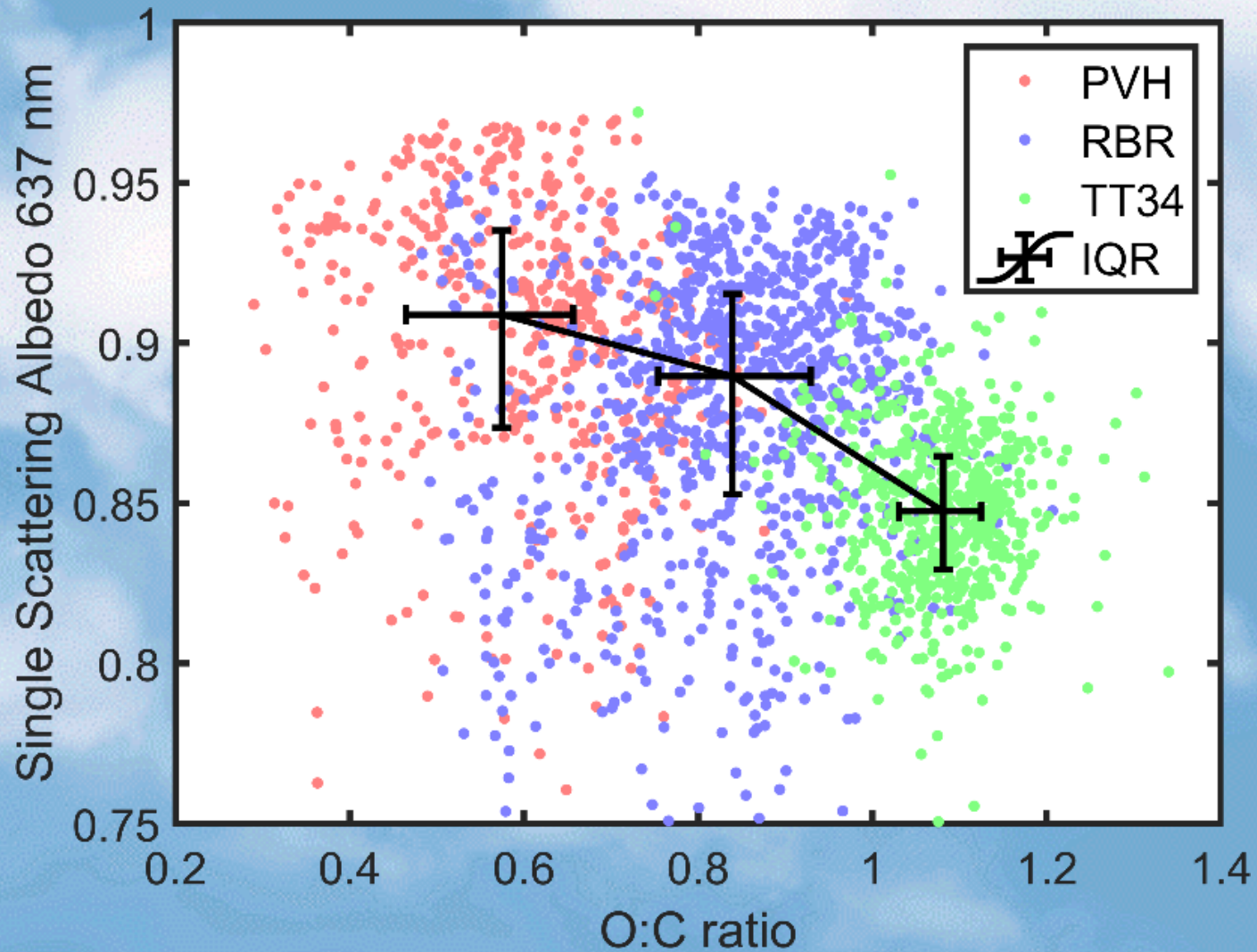

SSA decreases with aerosol ageing

- ▶ **SSA decreasing trend** – A clear trend of SSA decrease (stronger relative absorption) has been observed between sites, and correlating with O:C ratio. This could be result of enhanced absorption with atmospheric ageing (e.g. formation of Brown Carbon (BrC)). (Joel Brito, 2019)

Fate of isoprene RO2 radicals (ISOPO2) depicting different chemical pathways that depend on the NOx, HOx, and RO2 regimes. Several pathways lead to SOA formation, but the particle loading/composition differs greatly between different regimes, and also depends on acidic/non-acidic seeds.

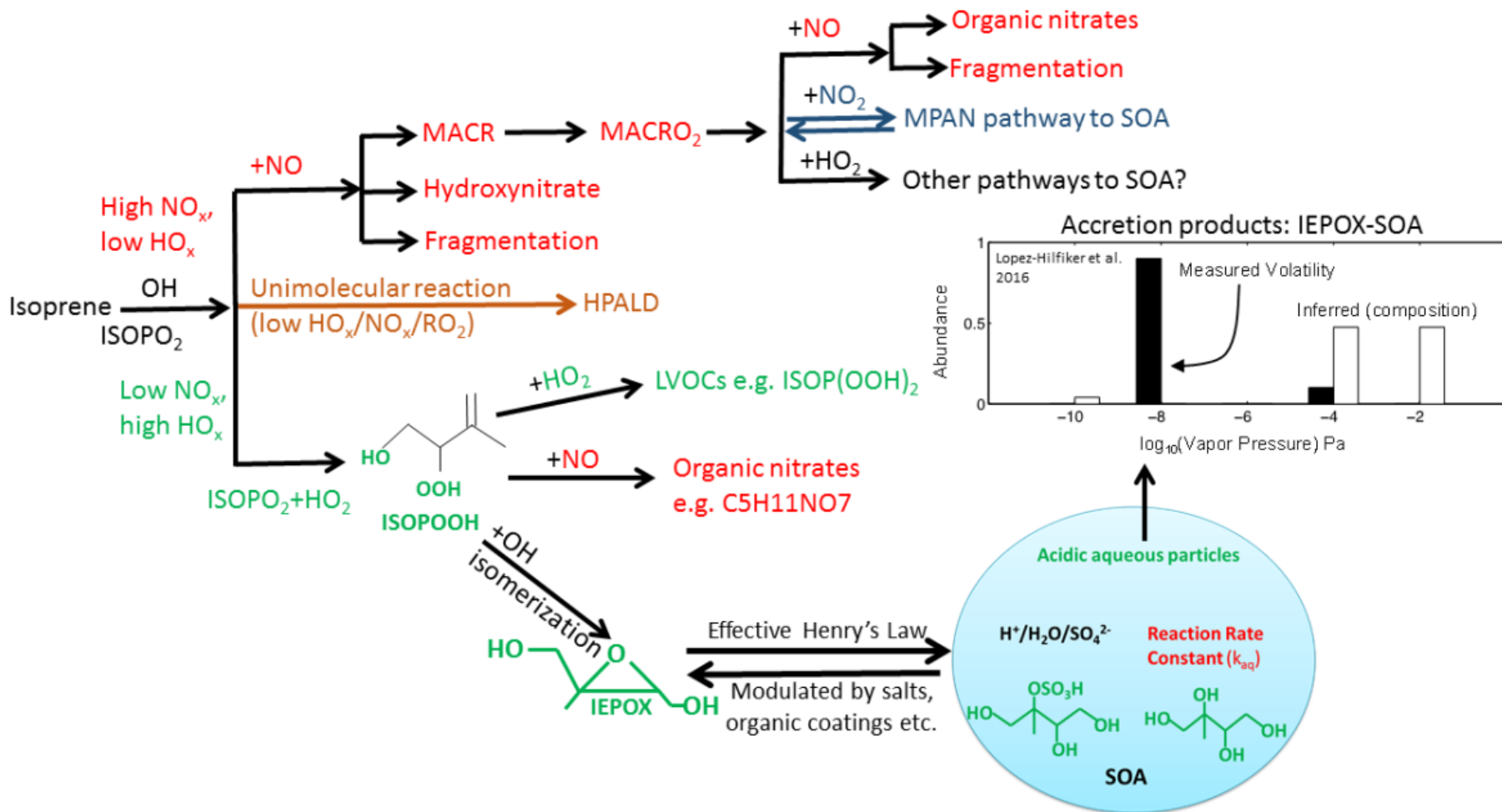

Influence of anthropogenic emissions on isoprene-derived particulate matter in central Amazonia

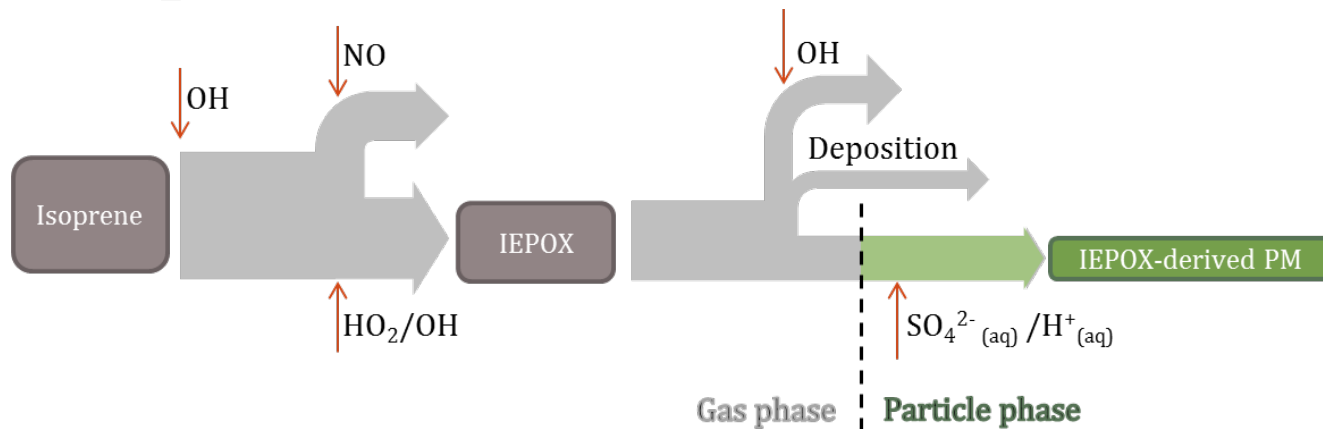

- Observational constraints of sulfate as a first order predictor and NO_y as a modulator of IEPOX-derived PM.
 - NO_y serves as indicator of integrated exposure of air mass to NO chemistry.
 - IEPOX-SOA factor obtained from PMF analysis of AMS data is a proxy for IEPOX-derived PM.
- Lower loadings of IEPOX-SOA factor observed for polluted compared to background conditions

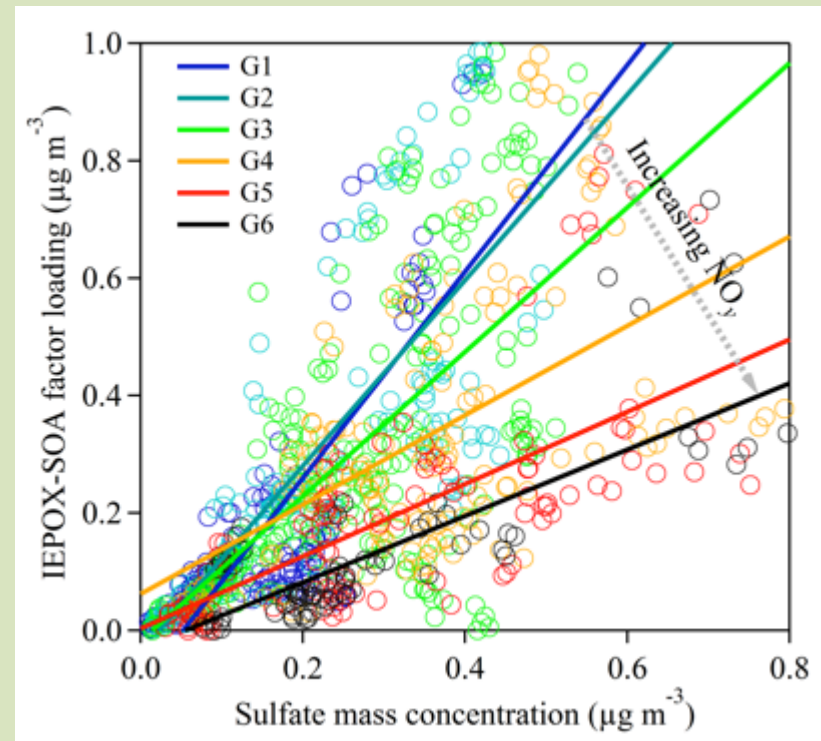

The T3 research site



Intensive Operation Periods (IOPs) - 2014

IOP1: wet season
Feb 1 – Mar 31

IOP2: dry season
Aug 15 – Oct 15

Aerosol Mass Spectrometry

HR-ToF-AMS
 Aerodyne
 High-resolution
 Time-of-Flight
 Aerosol Mass
 Spectrometer
 (AMS)

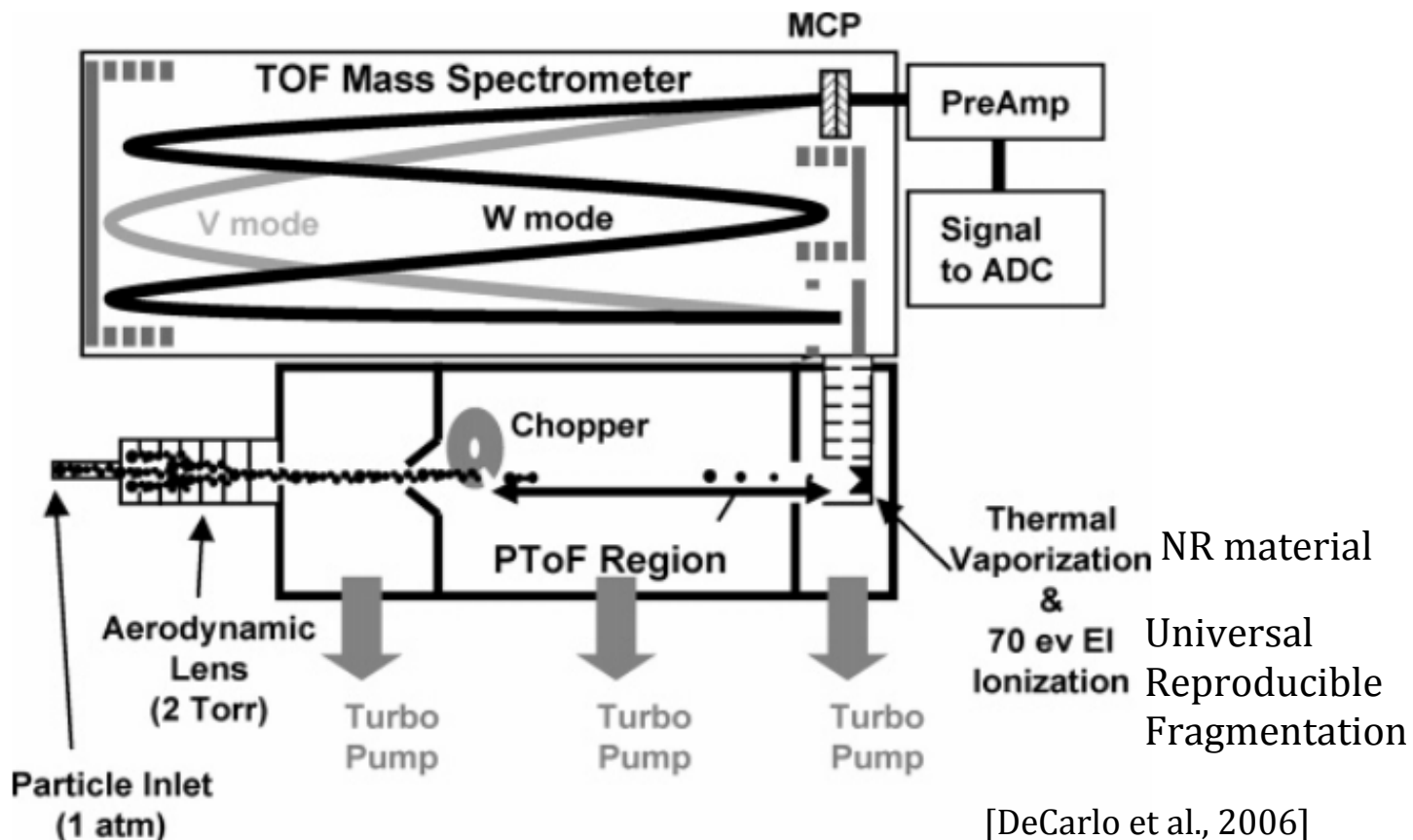

Non-refractory PM1

- Mass concentrations: Organic, Sulfate, Ammonium, Nitrate, Chloride
- Chemically resolved mass-size distribution
- Mass spectra, EI → “fingerprint”

SV-TAG - semi-volatile thermal desorption aerosol gas chromatograph with in situ derivatization, which provides hourly resolved concentrations and gas-particle partitioning of most common BVOC oxidation tracers

SOAS+GoAmazon: The results of the present study show that the gas-particle partitioning of approximately 100 known and newly observed oxidation products is not well explained by environmental factors (e.g., temperature). Compounds having high vapor pressures have higher particle fractions than expected from absorptive equilibrium partitioning models. Many commonly measured biogenic oxidation products may be bound in low-volatility mass that decomposes to individual compounds on analysis

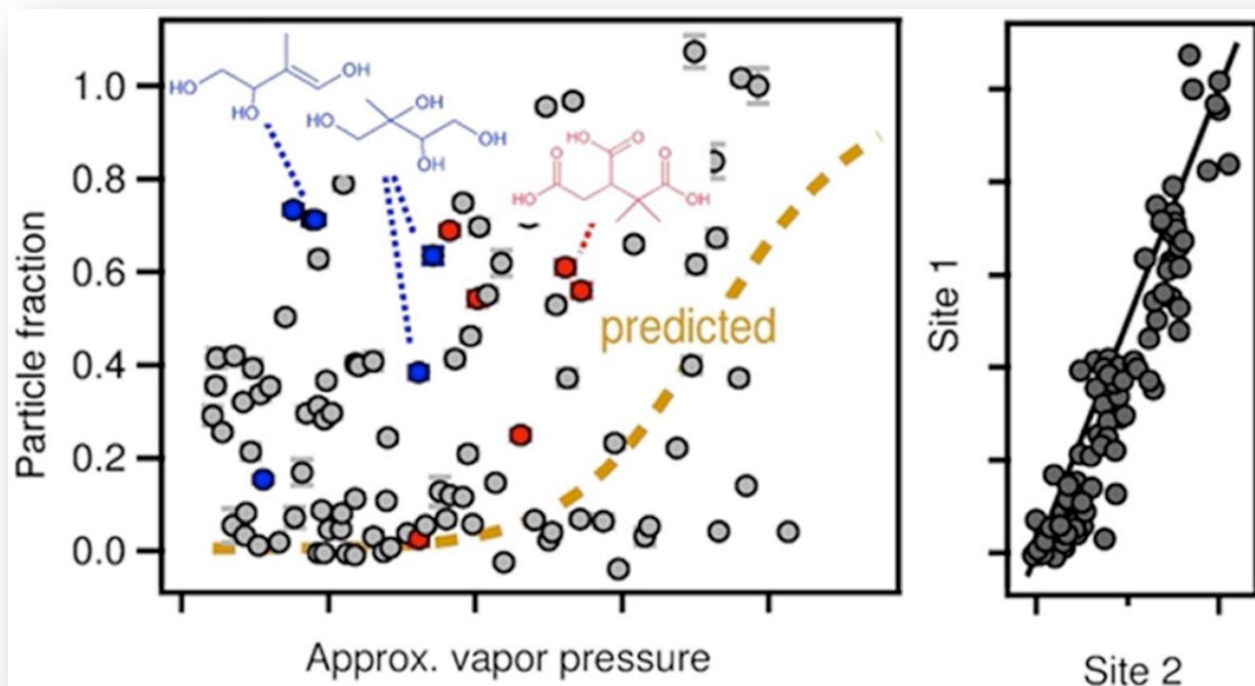

More Secondary Aerosol Potential than Expected

Objective:

Test through in situ data sets the potential for secondary aerosol production and compare to state of understanding with respect to known species and their reactive yields

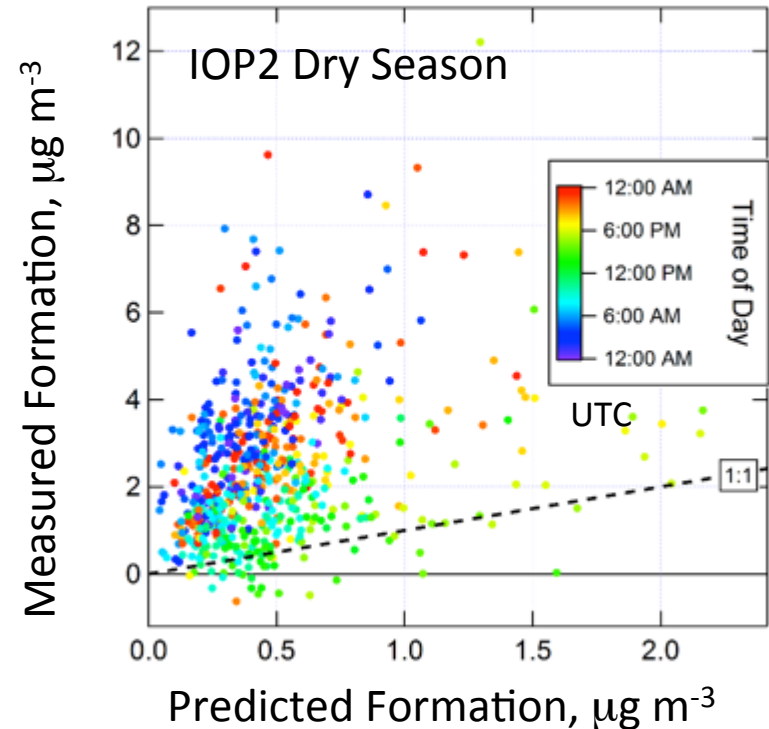
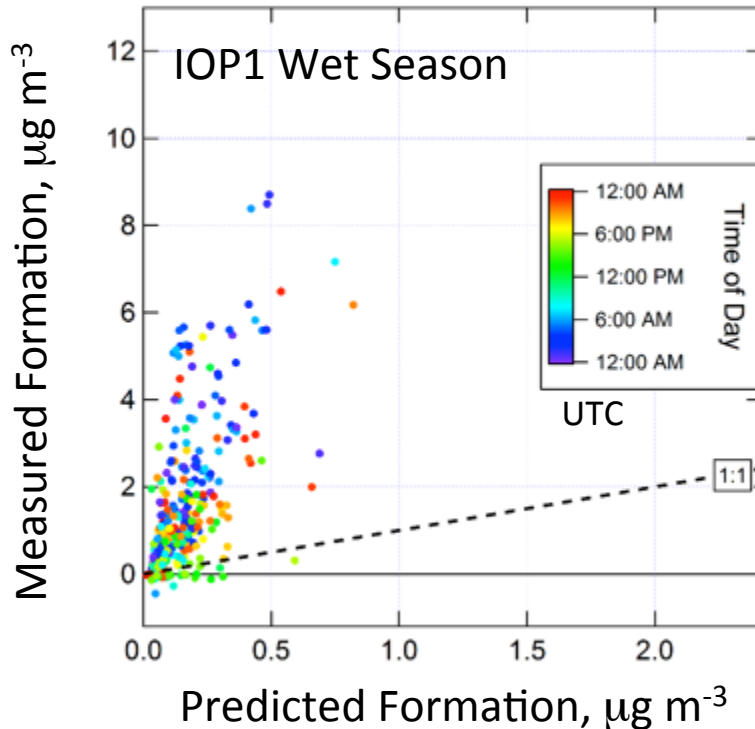

Results:

- Secondary aerosol produced from oxidation by OH of ambient air
- Production much greater than predicted from modeled yields of measured ambient precursors
- Suggests that production is dominated by unmeasured species



Particle composition at T3

**IOP1
(Wet season)**

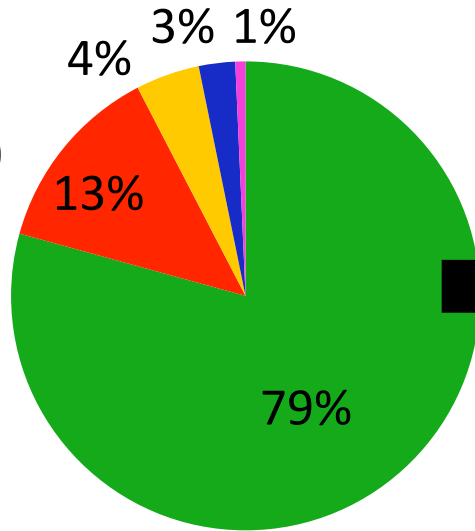

PMF

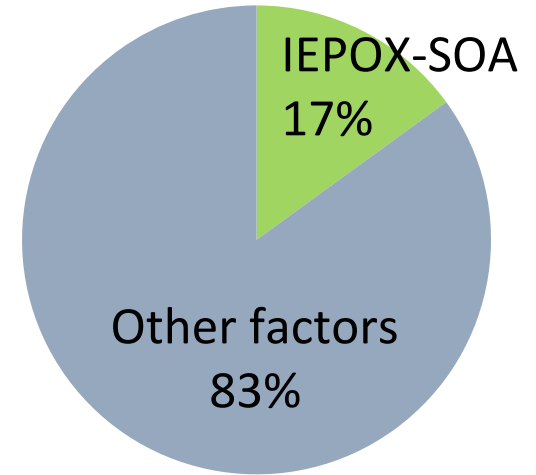

**IOP2
(Dry season)**

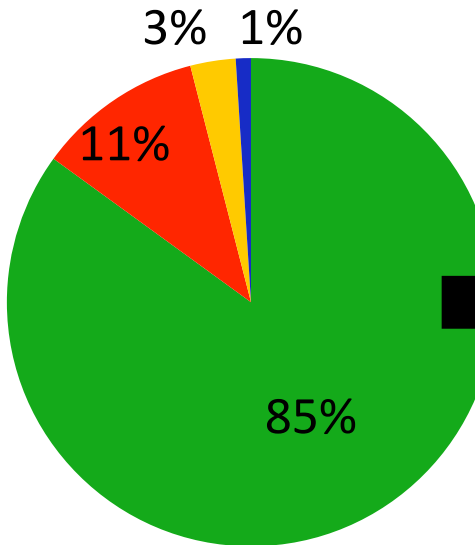

PMF

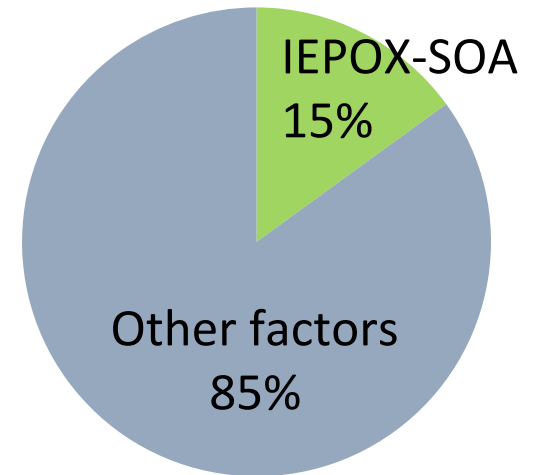

Organic
Sulfate
Ammonium
Nitrate
Chloride

Wet season aerosol composition in central Amazonia

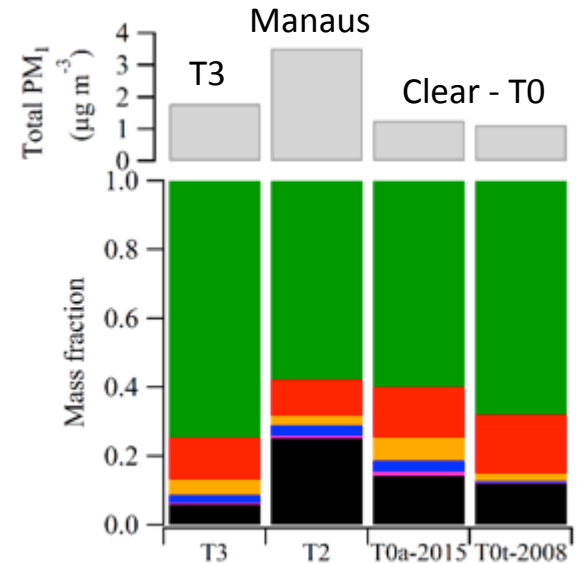
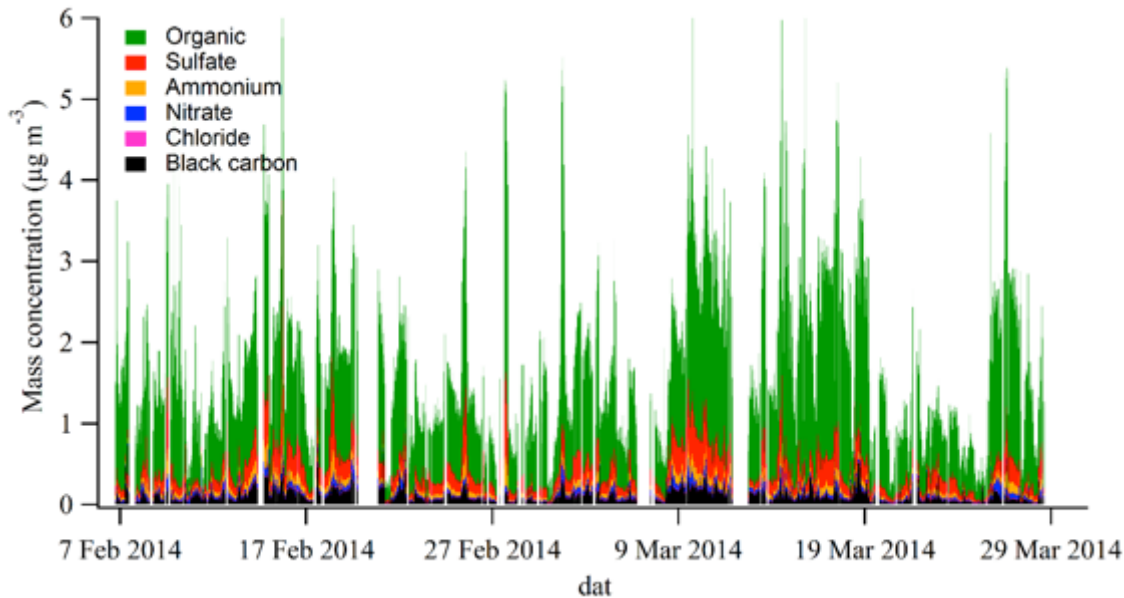

3.2. Source apportionment of organic PM

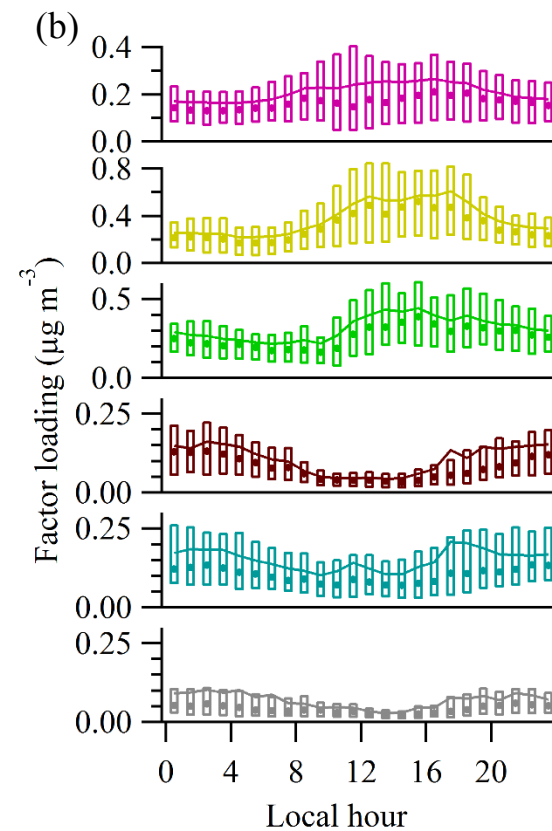
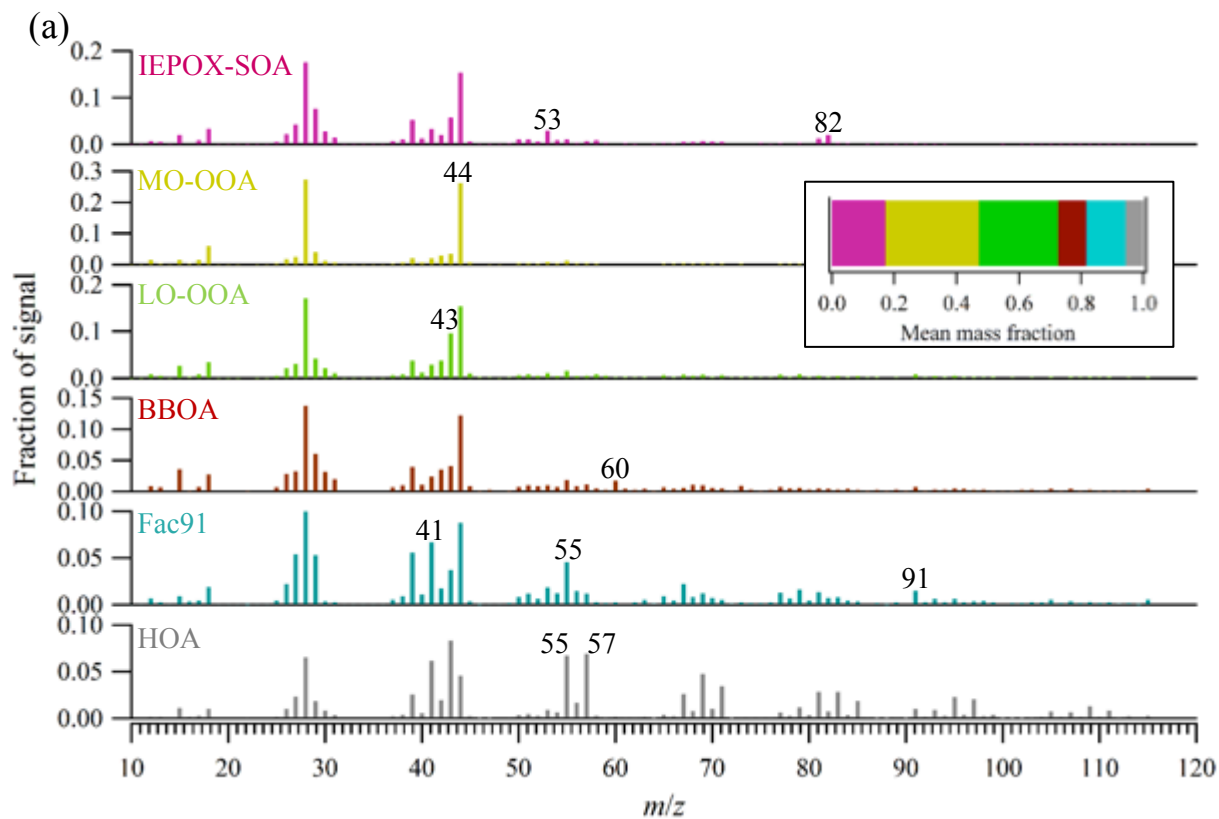
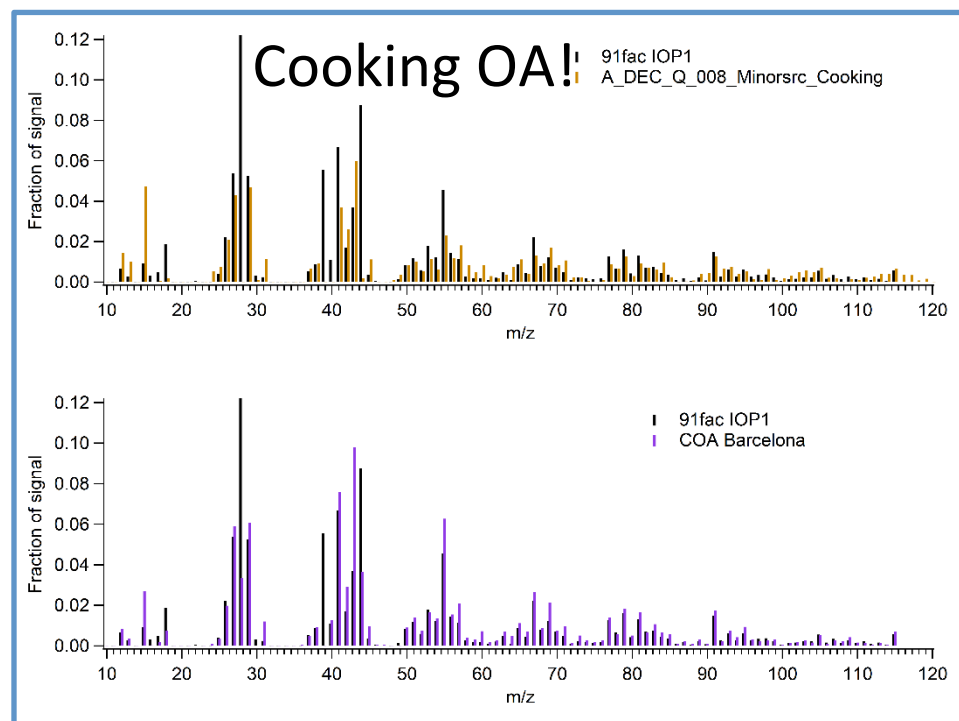
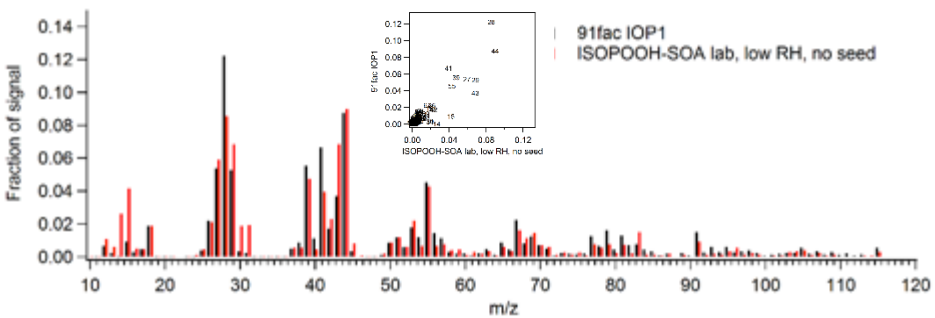
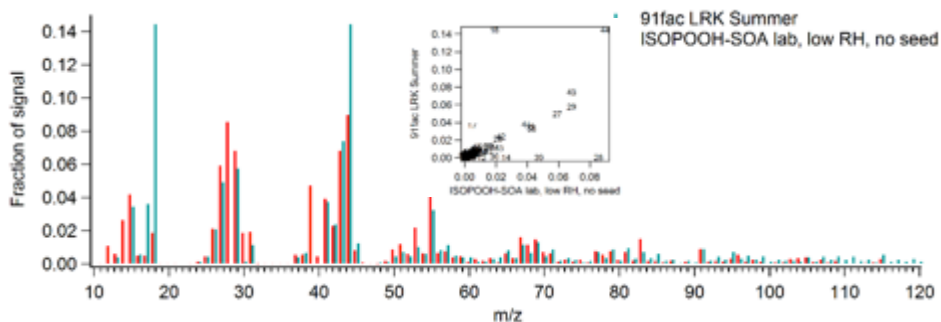
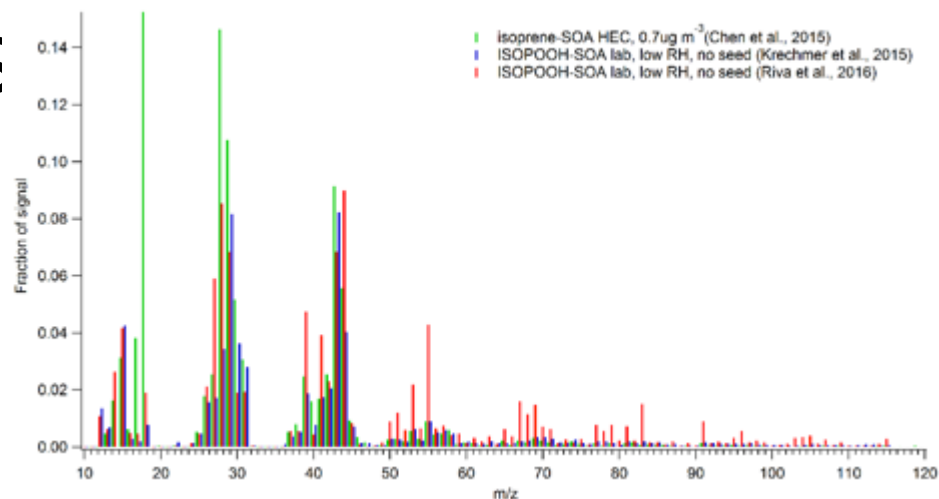
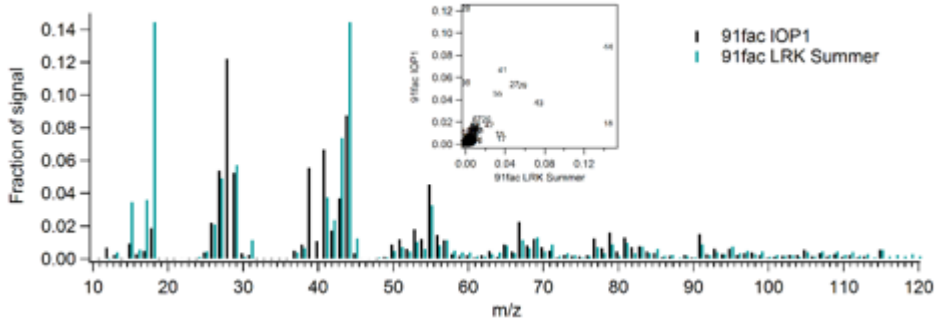

Figure 3

Fac 91 (parenthesis)

Bio-anthrop. SOA?



Shifts in aerosols with anthrop. influences

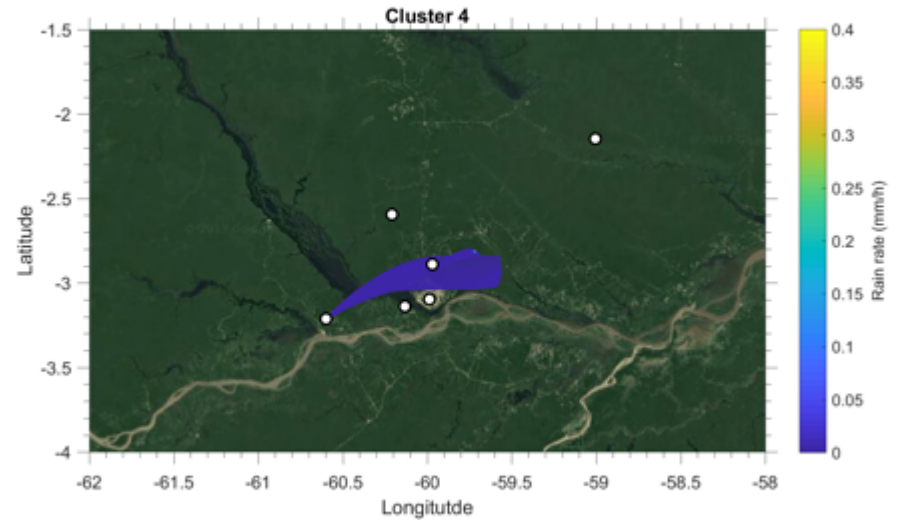
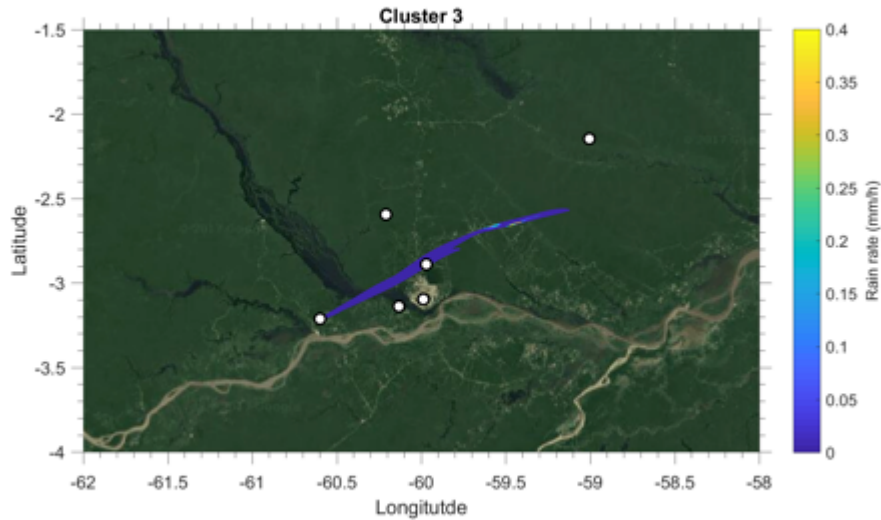
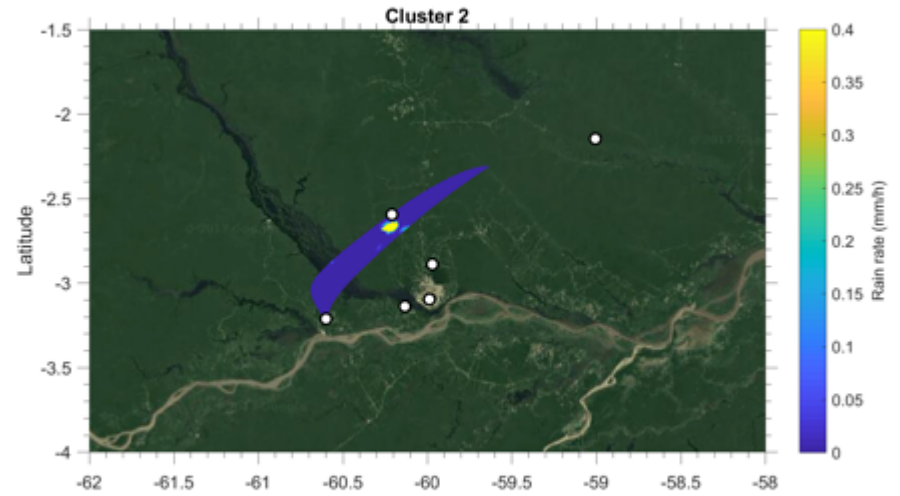
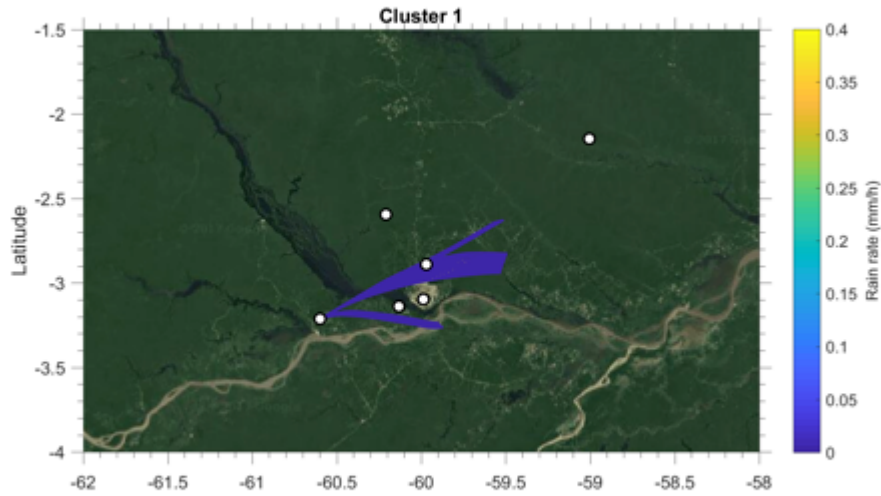

Deriving a pollution index with Cluster analysis

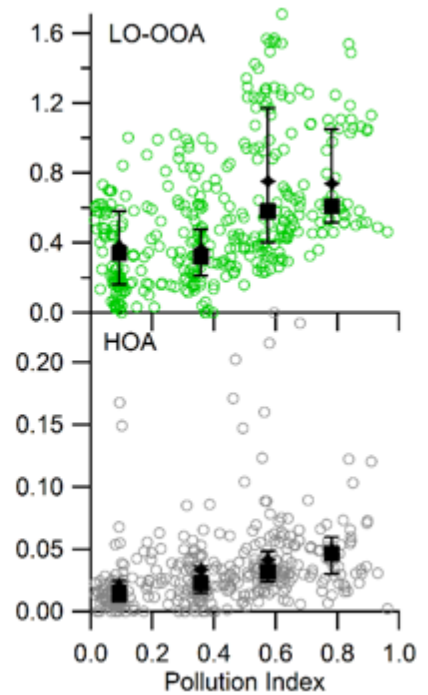
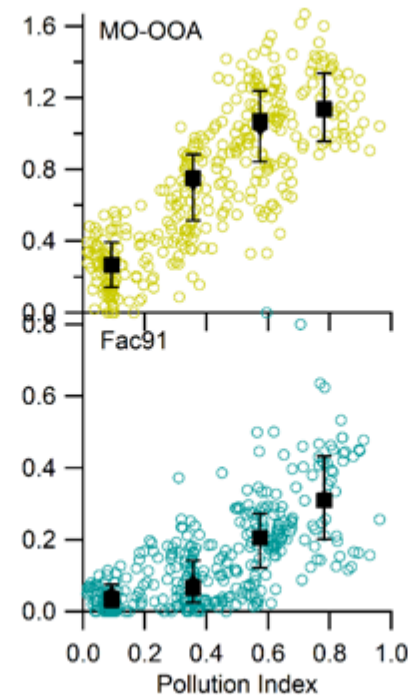
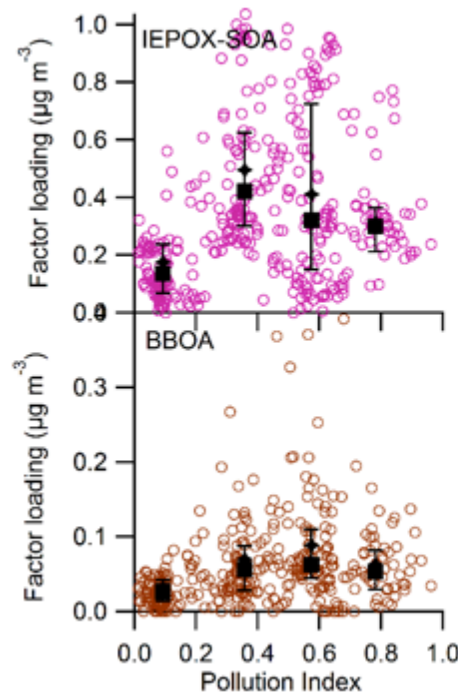
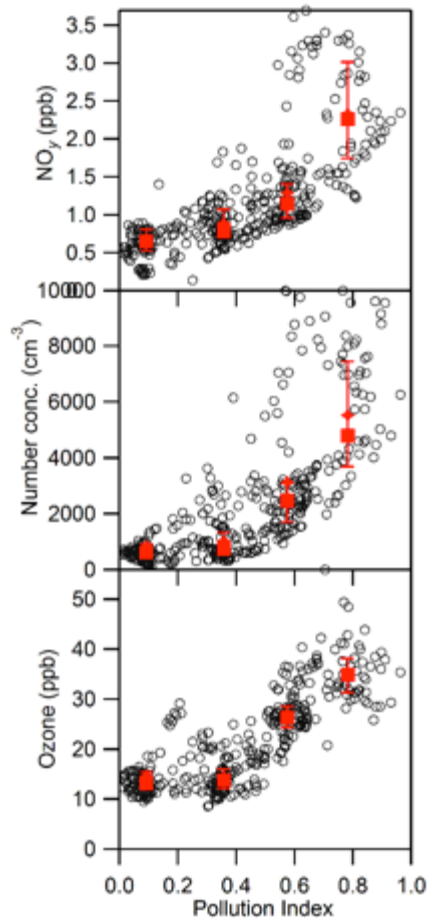

- Conditions: afternoon (12-16 LT), no rain (10h in traj), Sol rad (4h) > 200 W m⁻²
- Input variables: NO_y, O₃, logCPC, SO₄²⁻, NO₃⁻, NH₄⁺, Cl⁻, BC

Shifts in PM with anthrop. influences

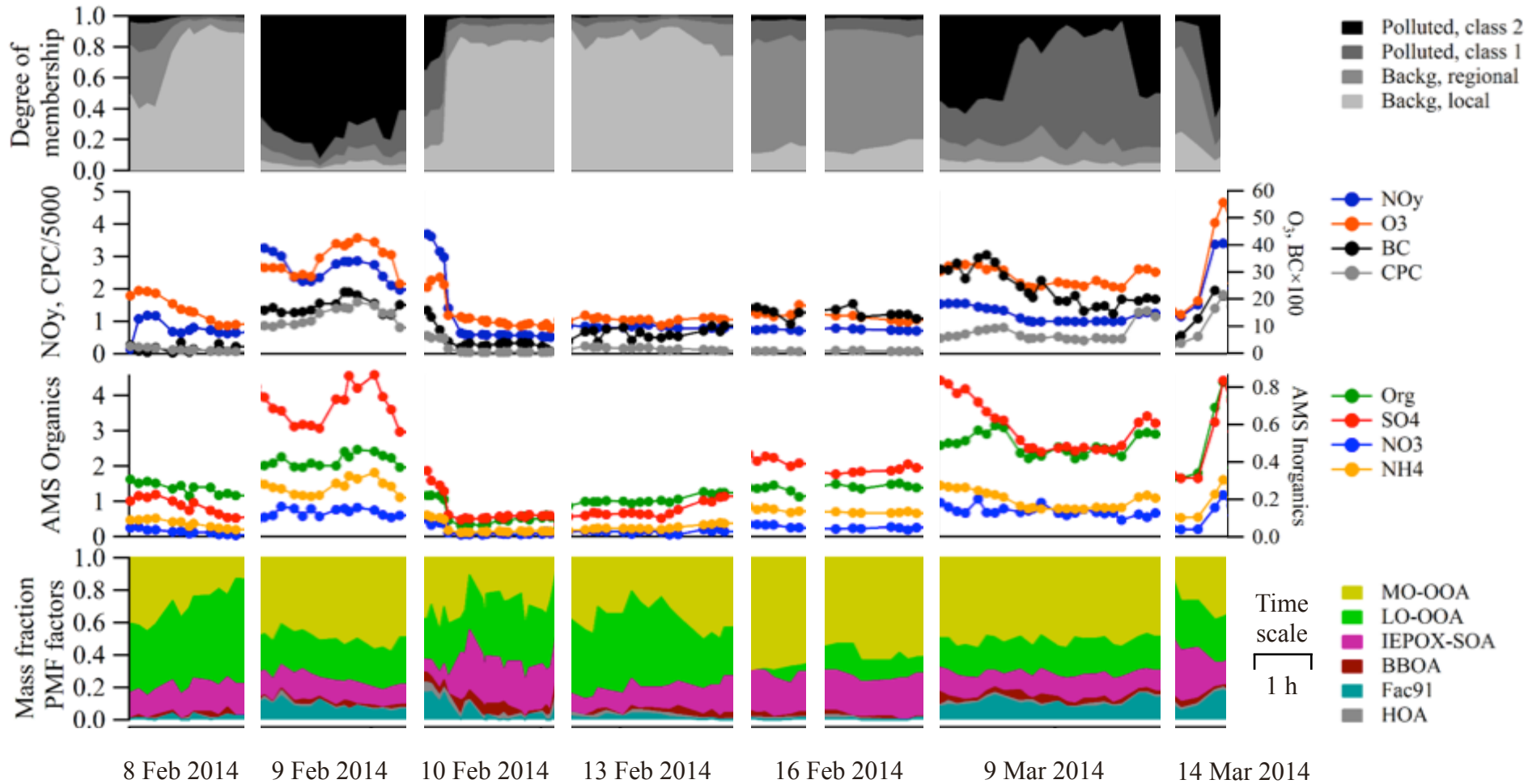

Shifts in aerosols with anthrop. influences

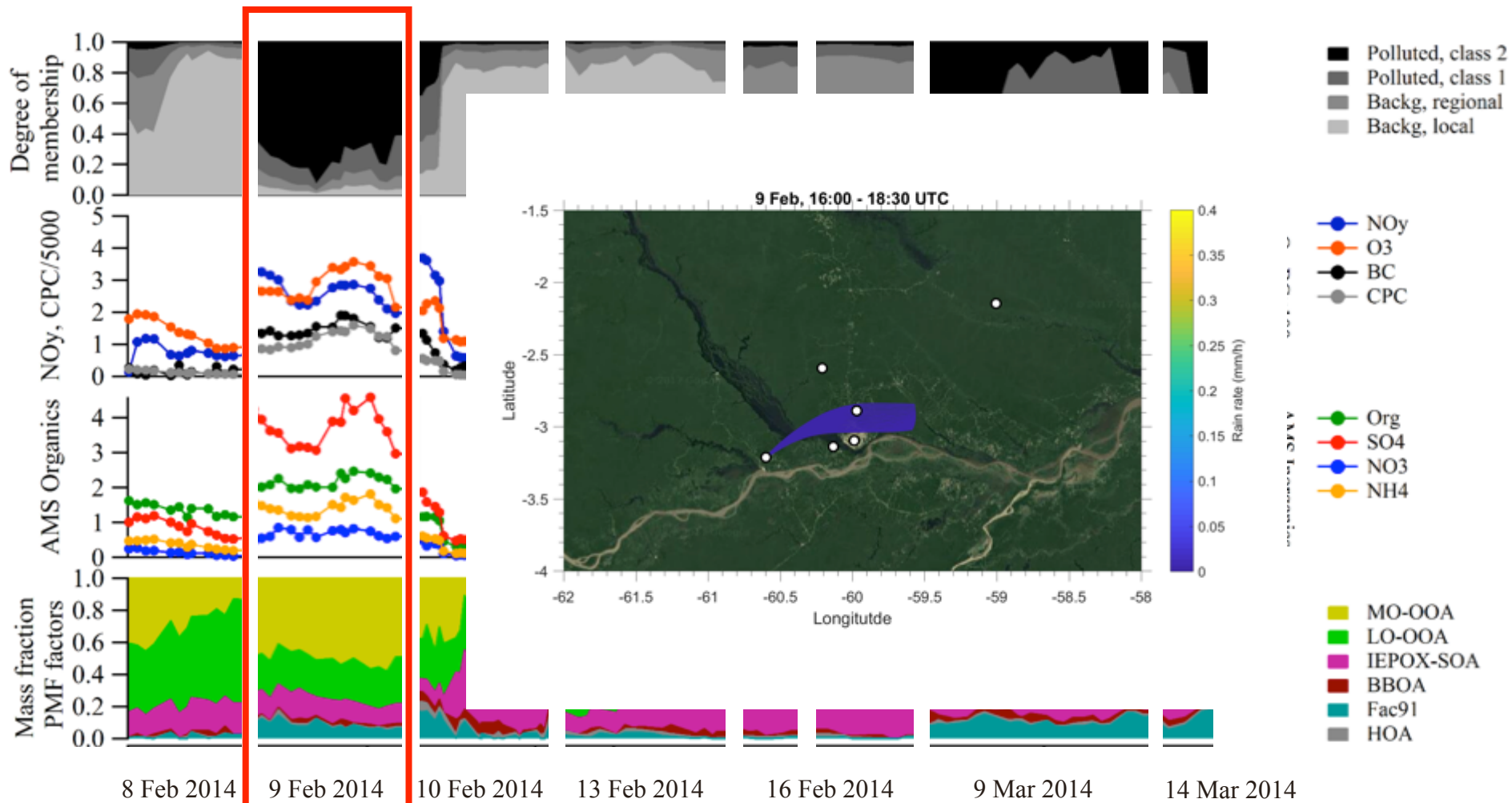

Figure 5

Shifts in aerosols with anthrop. influences

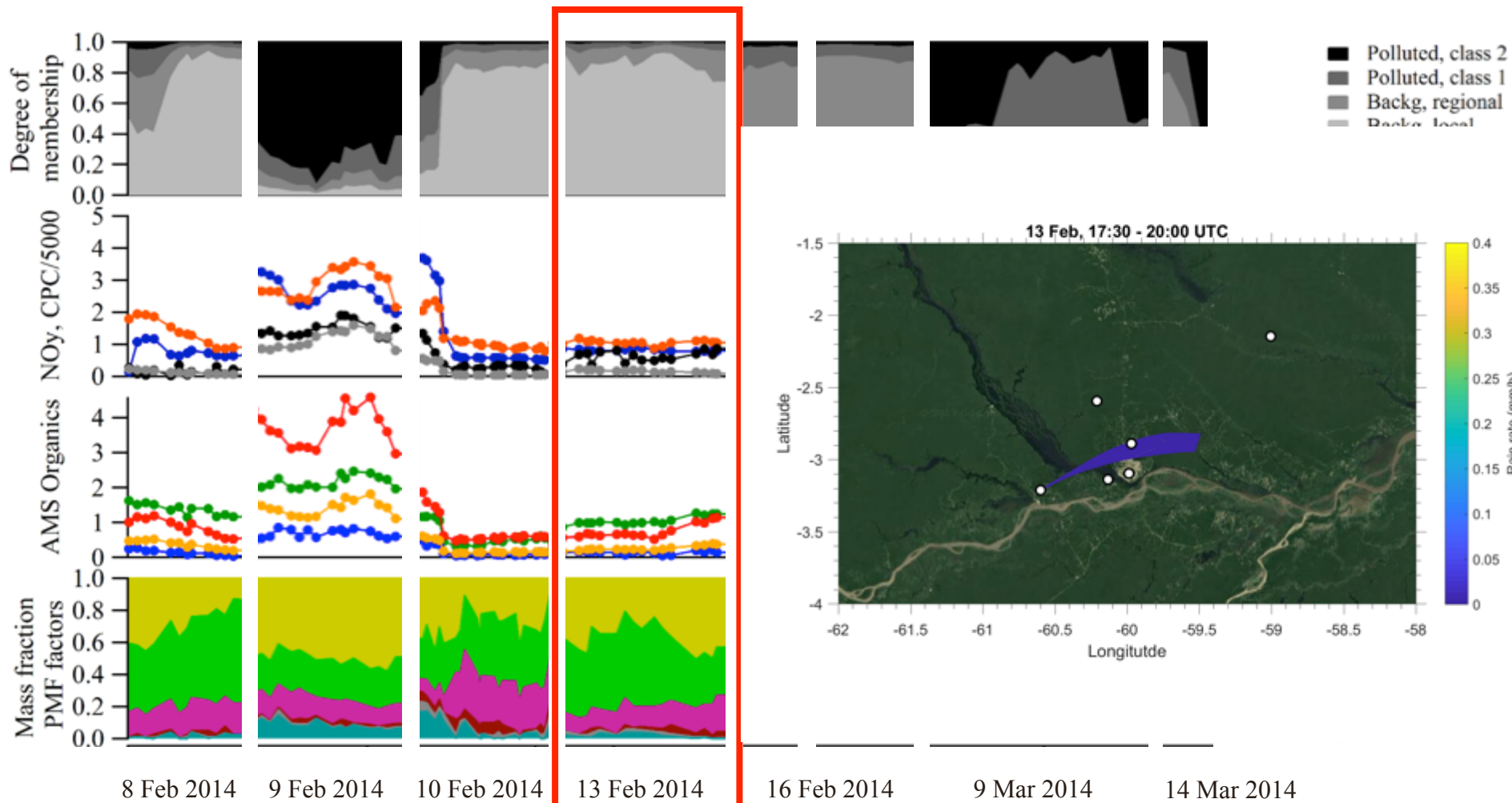
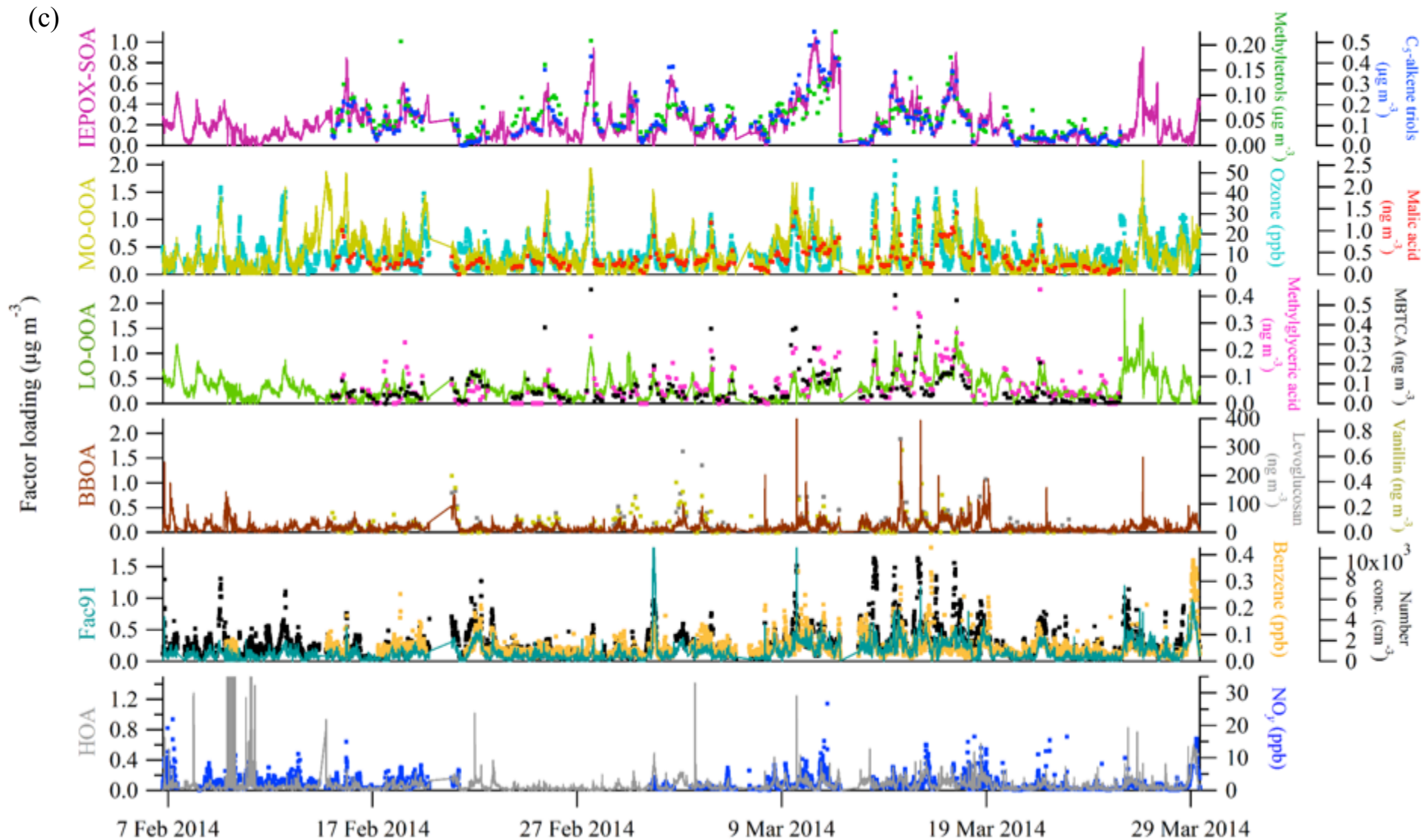

Figure 5

Source apportionment of organic PM



Suzane Sá, 2018

Source apportionment of organic PM – AMS + SV-TAG + PTR+ Others

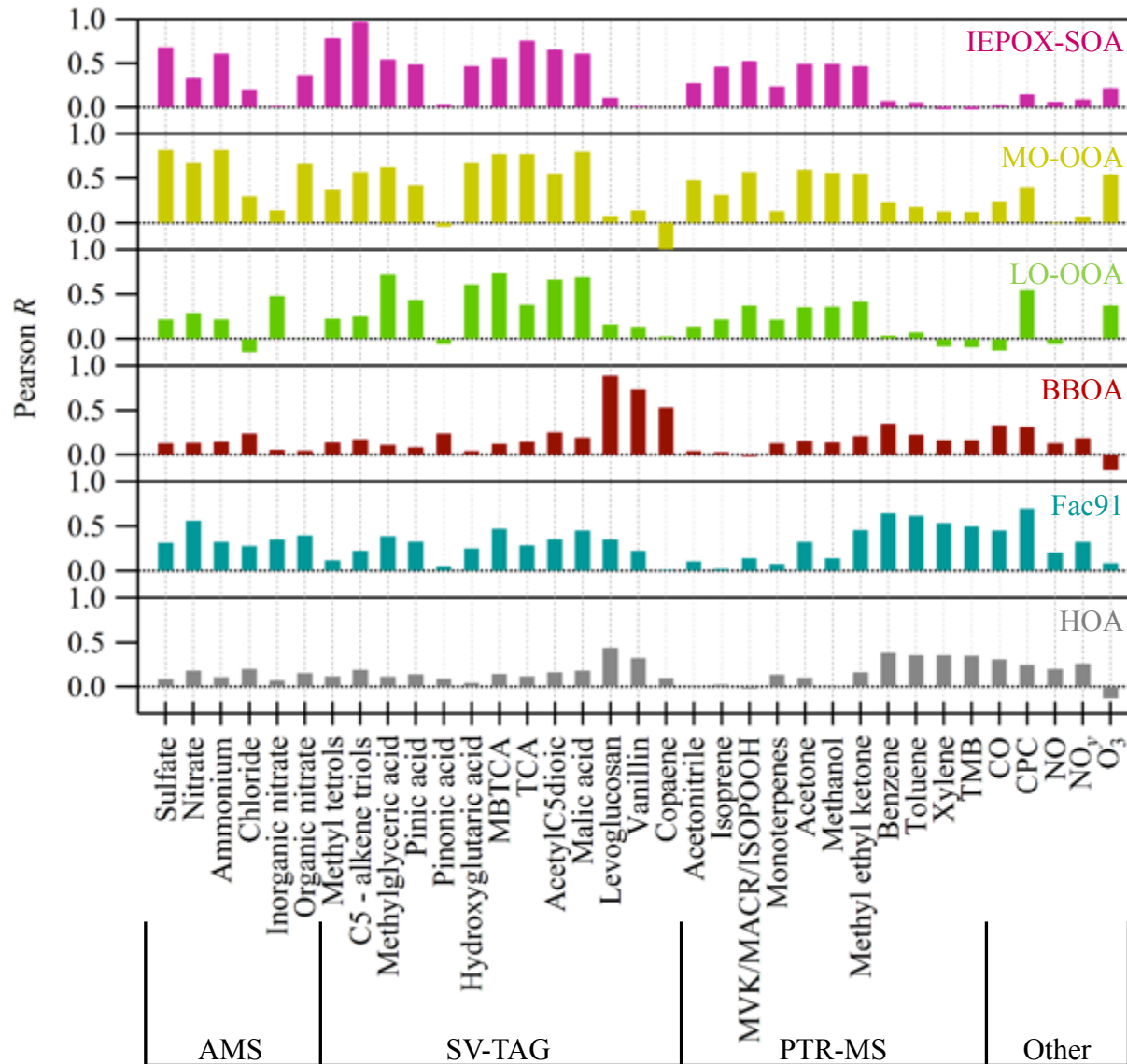

Shifts in aerosols with anthrop. influences

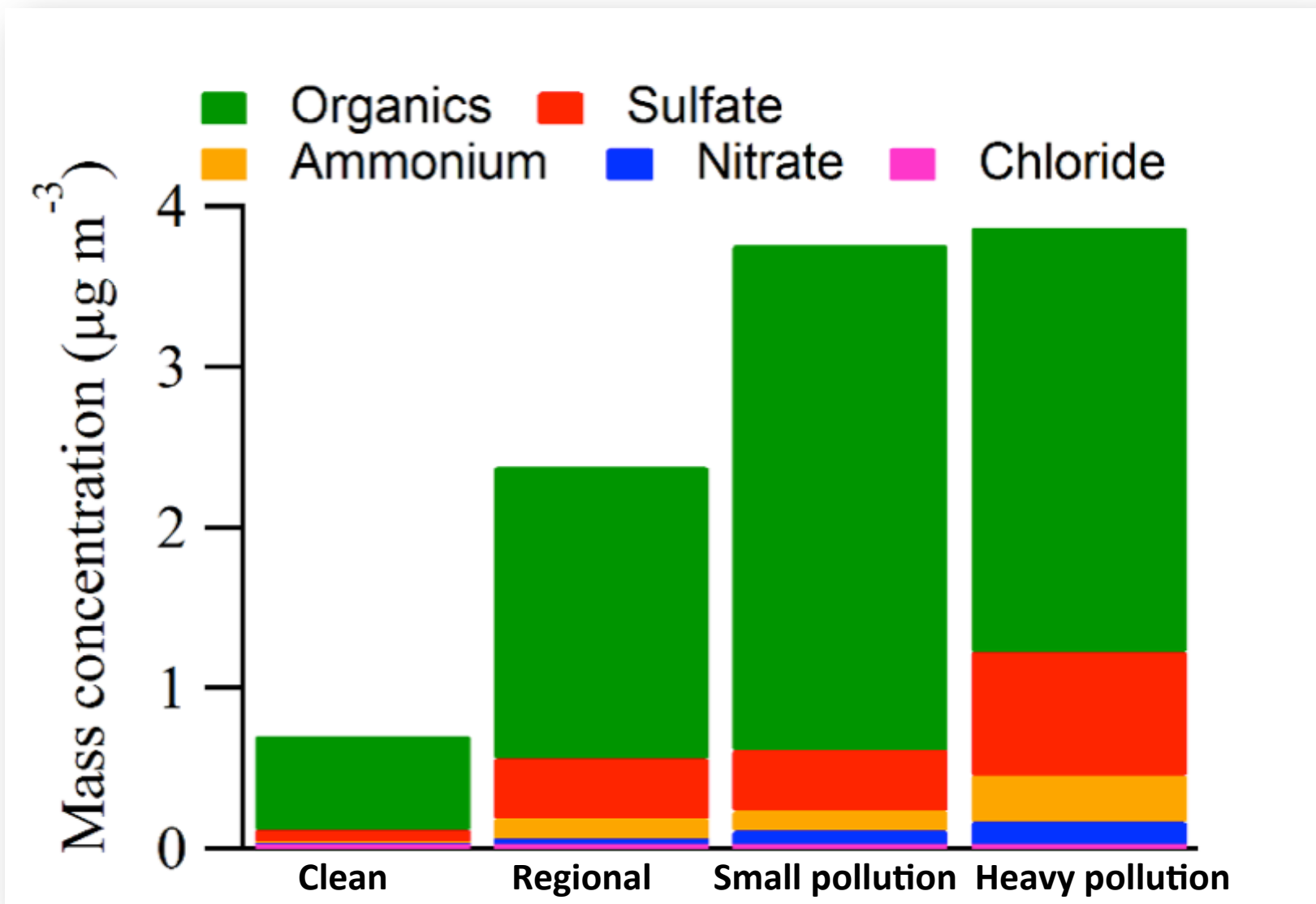

Increase in organic aerosols from 0.7 to 4 $\mu\text{g}/\text{m}^3$

SOA production in Amazonia DRY season

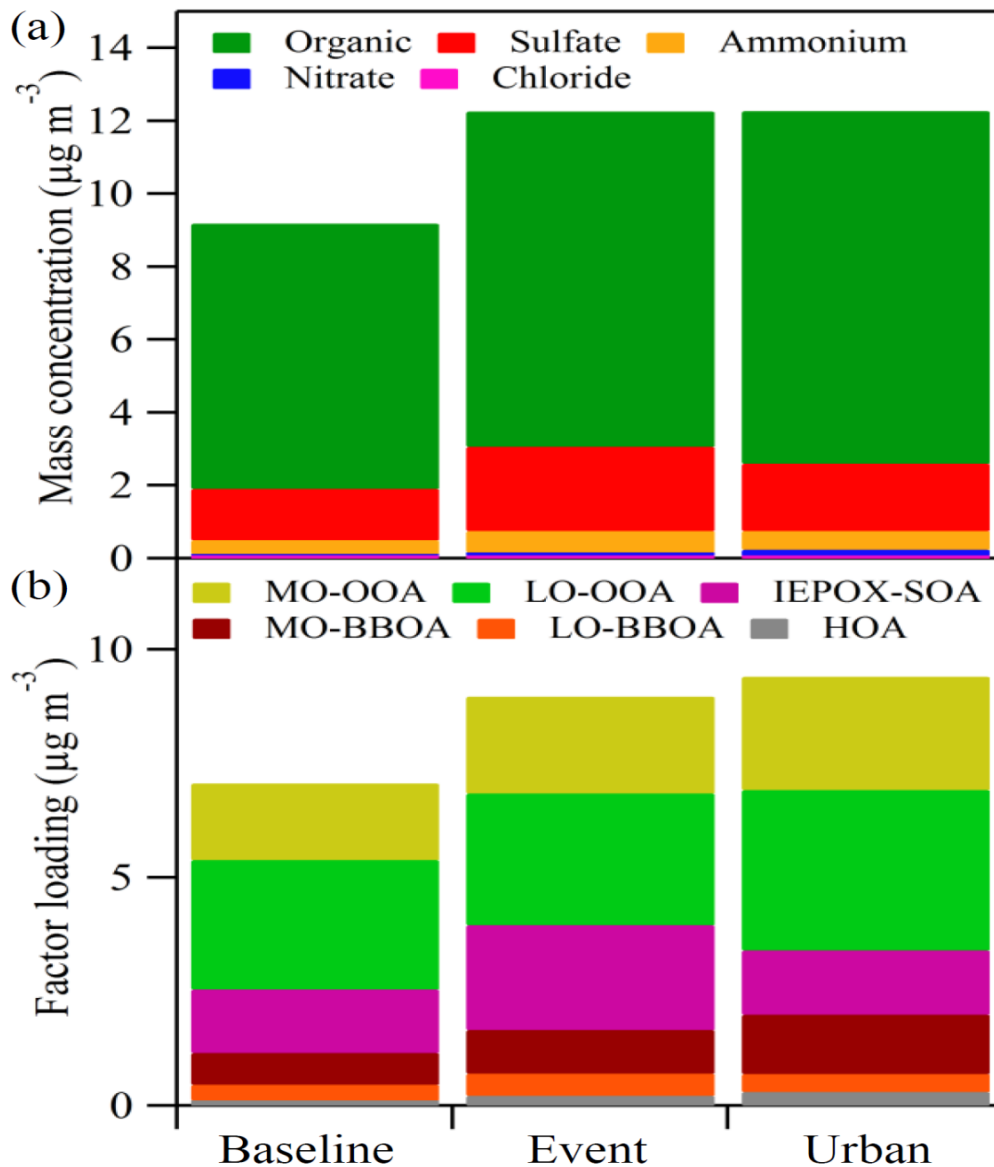

3.3. Shifts in PM with anthrop. influences

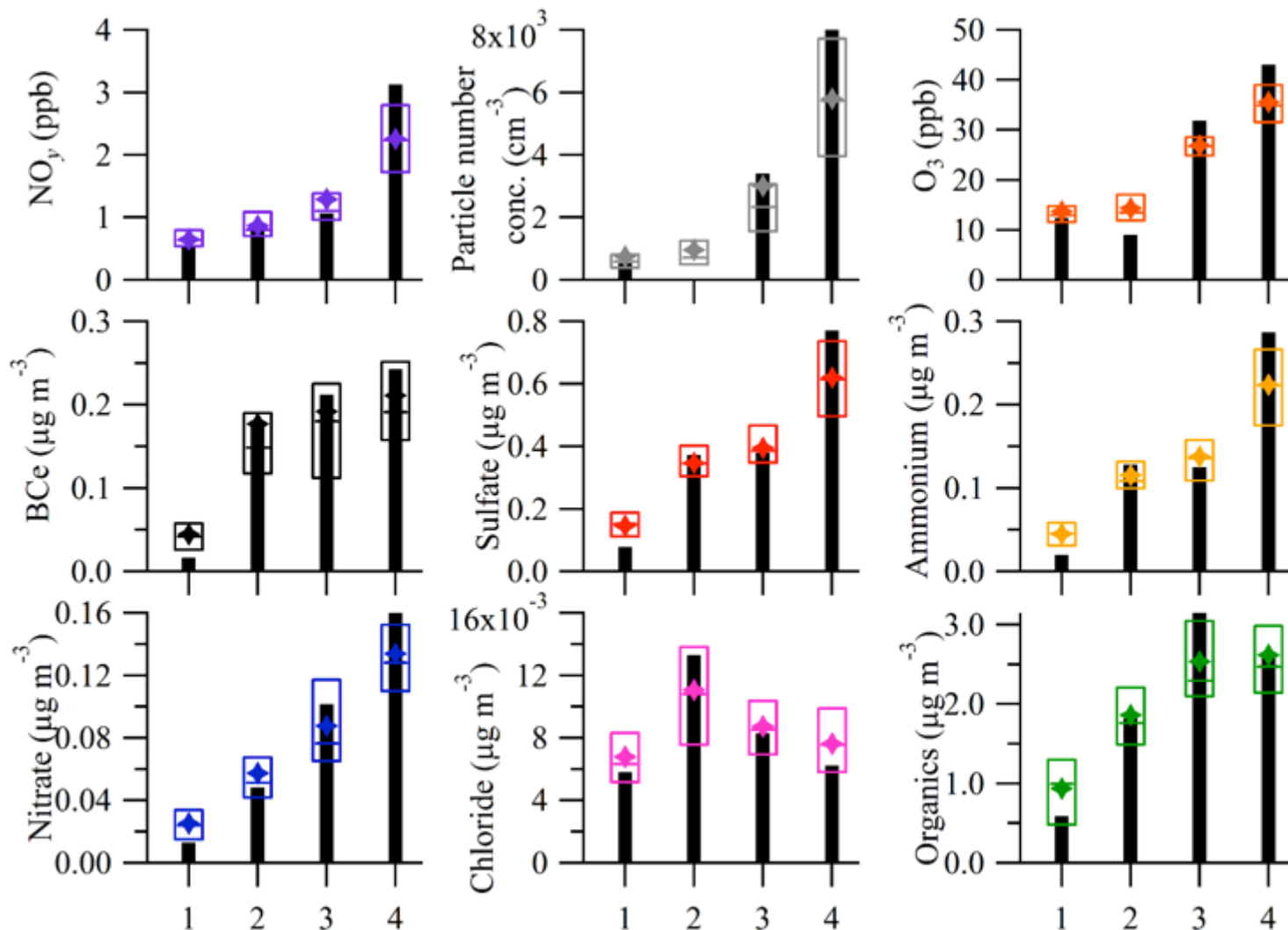

A very dynamic system with the interaction of the Manaus plume with the background air

Large temporal and spatial variability: a challenge for the models

Aerosol (HR-AMS) and Trace Gas (PTRMS) Composition

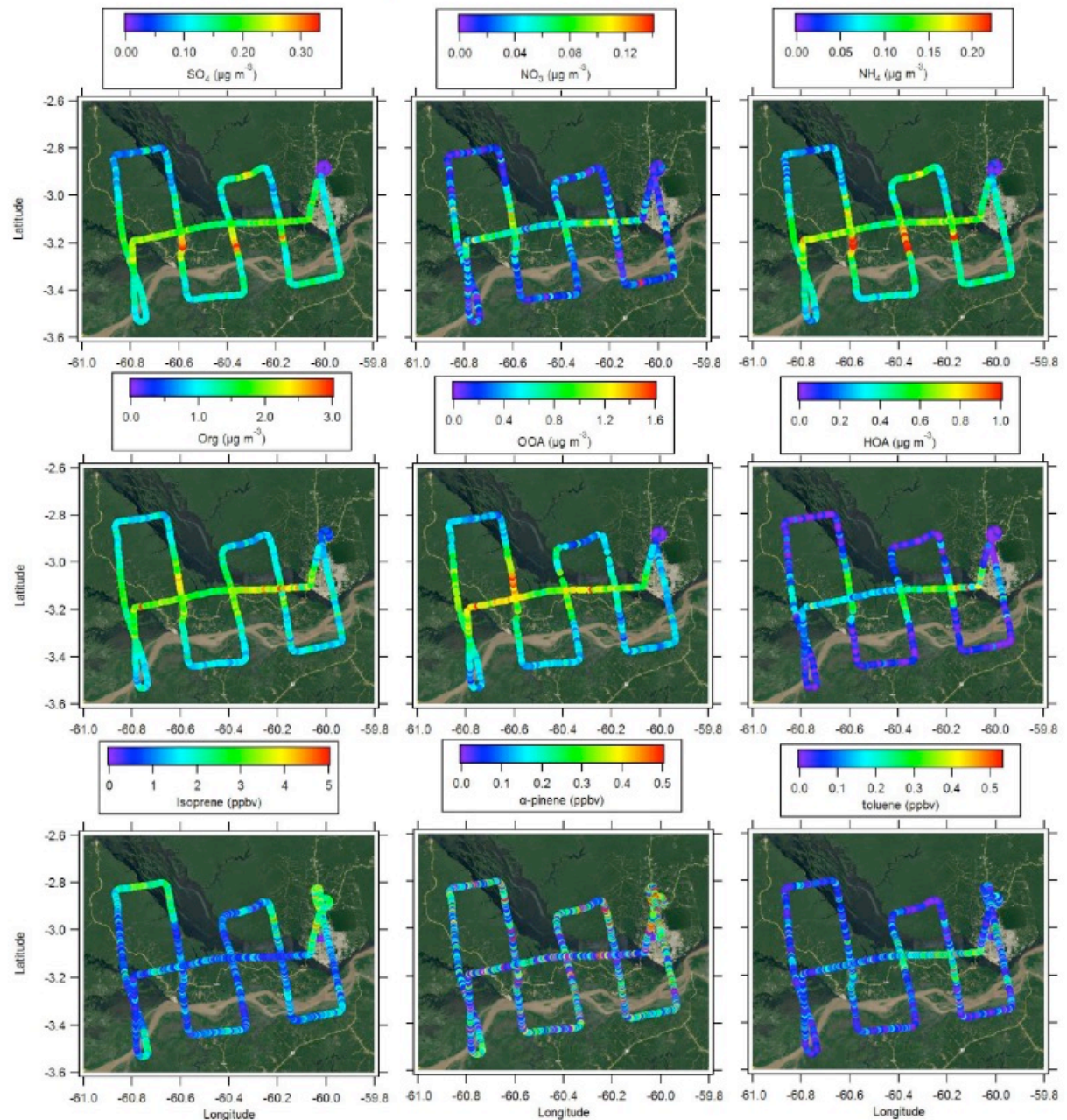

Transverse Transects of Urban Plume

500 m, 11 AM local, 13 March 2014

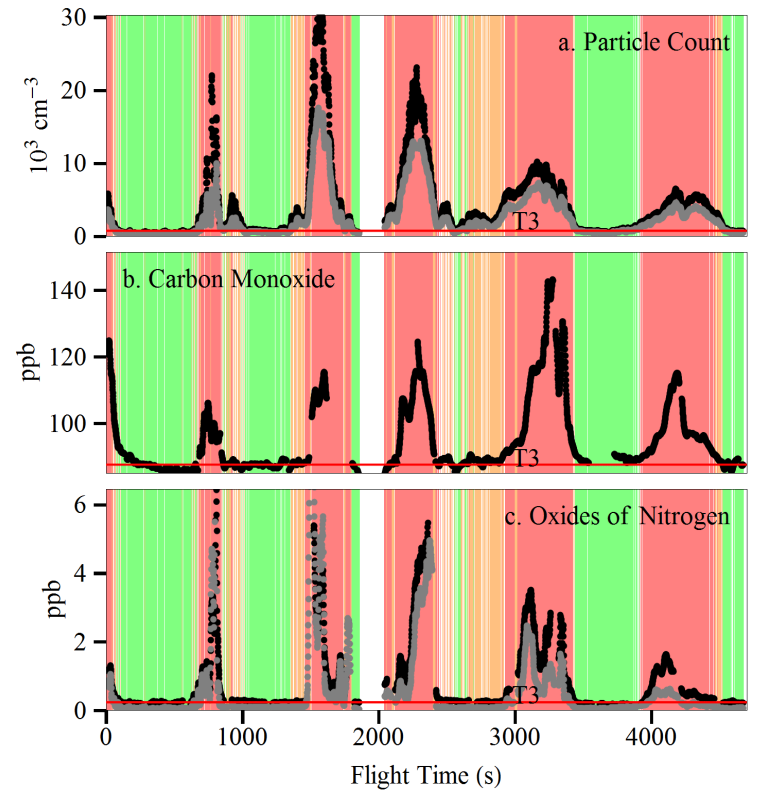
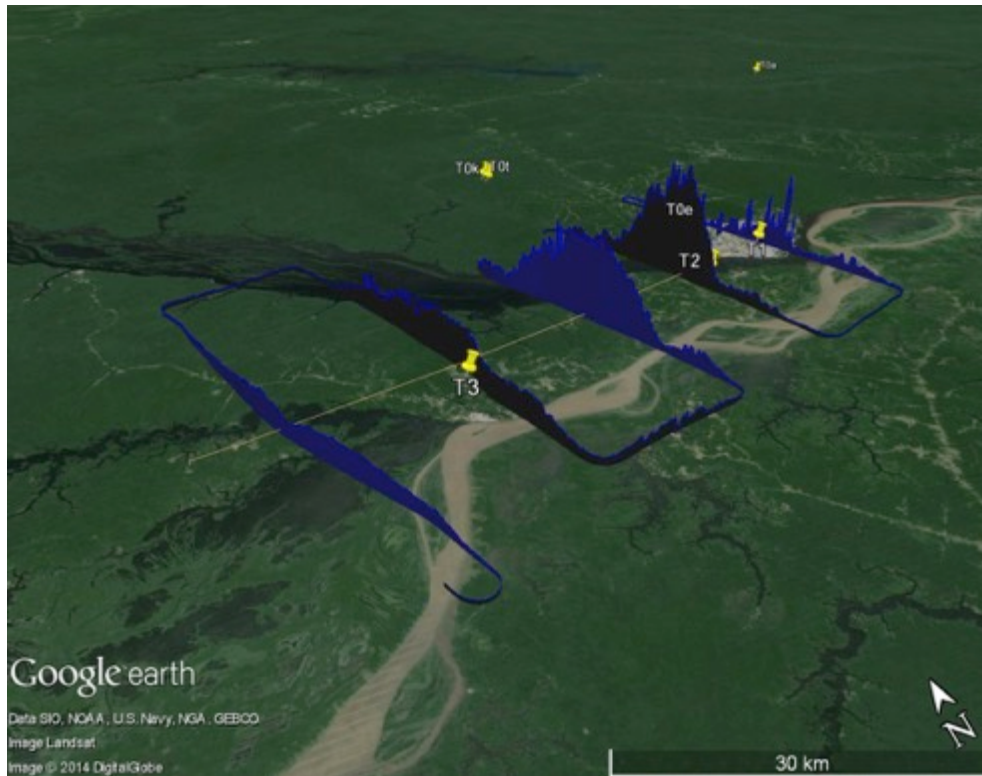

Data Sources: Mei Fan, Stephen Springston, IARA Experiment, DOE AAF G1 Platform

Aircraft Observations of Aerosol in the Manaus Urban Plume and Surrounding Tropical Forest during GoAmazon 2014/15

John E. Shilling¹, Mikhail S. Pekour¹, Edward C. Fortner², Paulo Artaxo³, Suzane de Sá⁴, John M. Hubbe¹, Karla M. Longo⁵, Luiz A.T. Machado⁶, Scot T. Martin^{4,7}, Stephen R. Springston⁸, Jason Tomlinson¹, Jian Wang⁸

GoAmazon 2014/5 Wet Season

GoAmazon 2014/5 Dry Season

Flight-Averaged Speciated Particulate Mass Loading

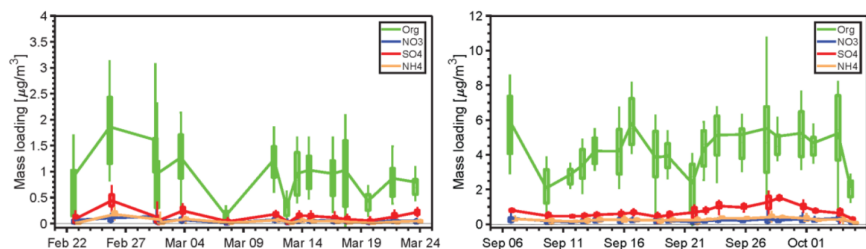

Flight-Averaged Particulate Fractional Composition

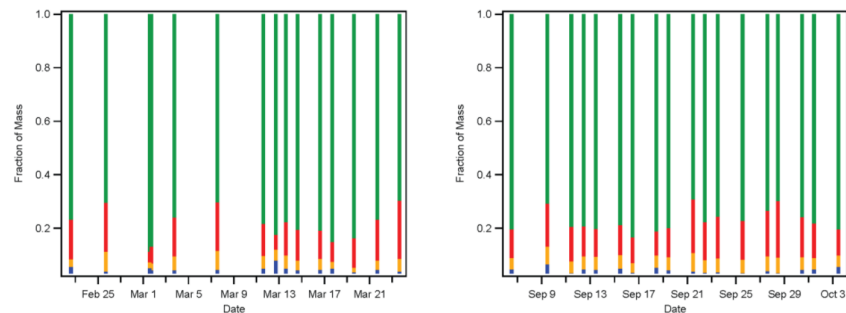

Averaged Particulate Fractional Composition

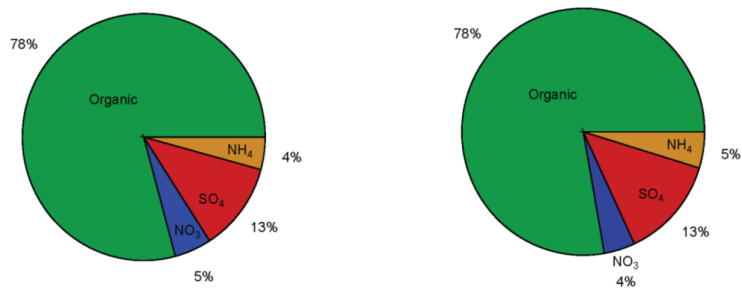

Box and whisker representations of the G-1 AMS data for both the wet and dry seasons (top panel), average particle chemical composition for each flight (middle panel), and average aerosol chemical composition for all flights (bottom).

Aircraft Observations of Aerosol in the Manaus Urban Plume and Surrounding Tropical Forest during GoAmazon 2014/15

John E. Shilling¹, Mikhail S. Pekour¹, Edward C. Fortner², Paulo Artaxo³, Suzane de Sá⁴, John M. Hubbe¹, Karla M. Longo⁵, Luiz A.T. Machado⁶, Scot T. Martin^{4,7}, Stephen R. Springston⁸, Jason Tomlinson¹, Jian Wang⁸

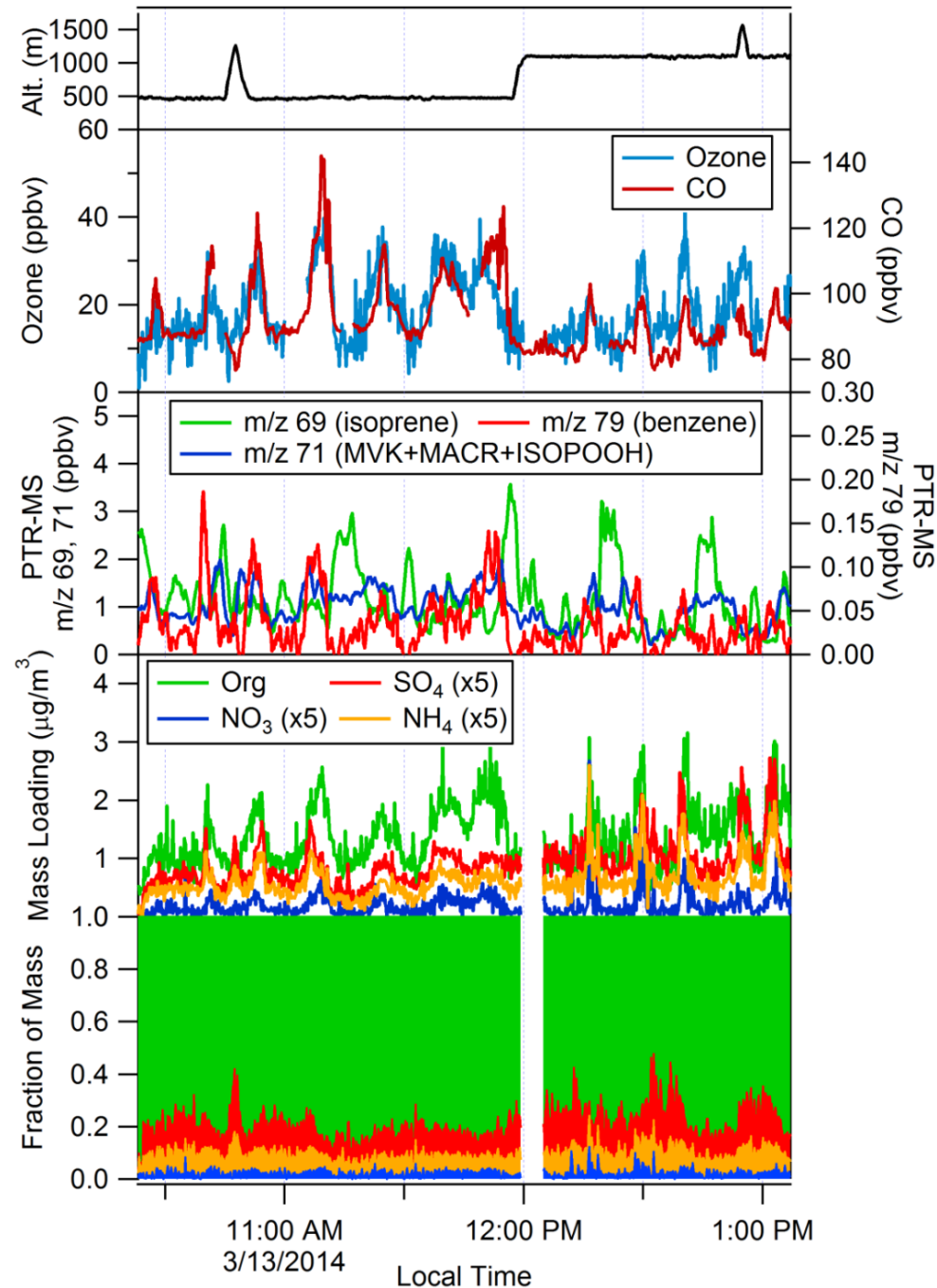

Time traces of relevant quantities on March 13th, 2014 flight. AMS data uses the HR-analysis routine described in the literature to minimize interferences (Aiken et al., 2007). Note the mass of inorganic species (SO_4 , NO_3 , NH_4) has been multiplied by a factor of five to improve the figure clarity. PTR-MS signal at m/z 69 corresponds to isoprene, m/z 71 corresponds to the sum of methylvinyl ketone (MVK), methacrolein (MACR), and isoprene hydroxyhydroperoxide (ISOPOOH), all oxidation products of isoprene, and m/z 79 corresponds to benzene.

Aircraft Observations of Aerosol in the Manaus Urban Plume and Surrounding Tropical Forest during GoAmazon 2014/15

John E. Shilling¹, Mikhail S. Pekour¹, Edward C. Fortner², Paulo Artaxo³, Suzane de Sá⁴, John M. Hubbe¹, Karla M. Longo⁵, Luiz A.T. Machado⁶, Scot T. Martin^{4,7}, Stephen R. Springston⁸, Jason Tomlinson¹, Jian Wang⁸

PMF analysis of the organic aerosol on the March 13th 2014 flight. The PMF analysis utilized the high resolution dataset. All data from the wet season were included in the analysis.

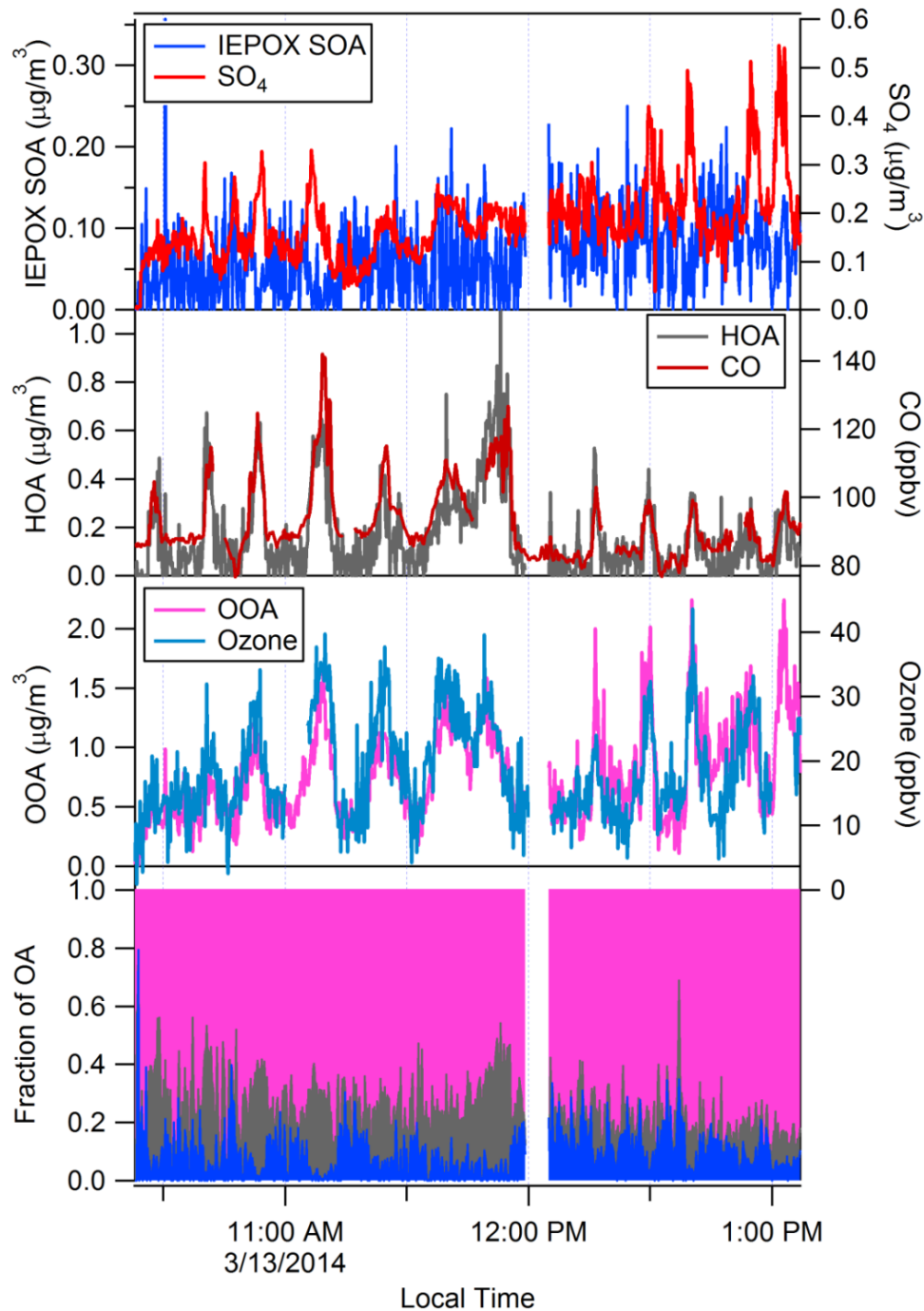

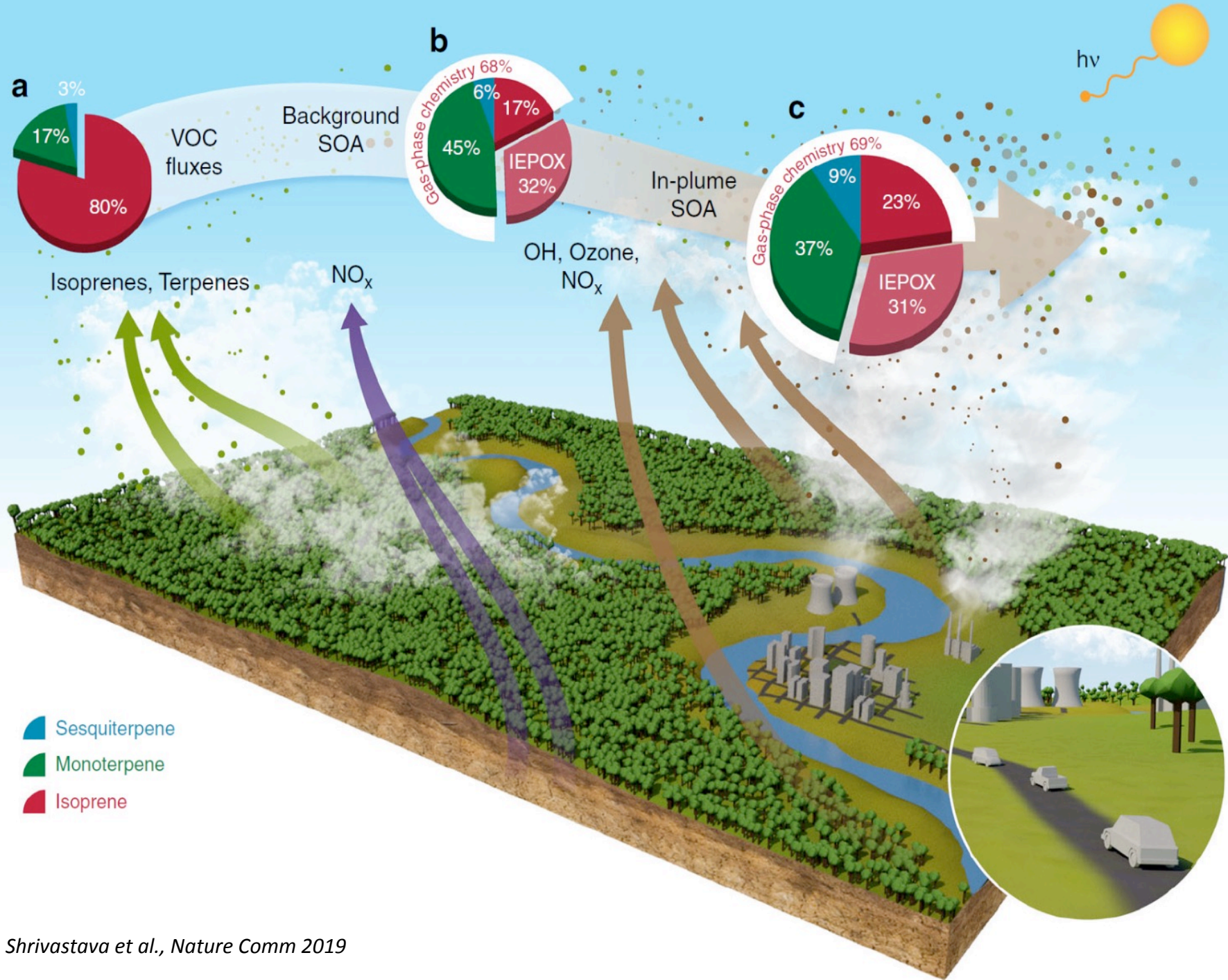

1 Strong pollution-enhanced biogenic SOA over the Amazon rainforest

2 Manish Shrivastava,^{1,*} Meinrat O. Andreae^{2,3}, Paulo Artaxo⁴, Henrique Barbosa⁴, Larry K. Berg¹,
 3 Joel Brito⁵, Joseph Ching^{1,6}, Richard C. Easter¹, Jiwen Fan¹, Jerome D. Fast¹, Zhe Feng¹, Jose D.
 4 Fuentes⁷, Marianne Glasius⁸, Allen H. Goldstein⁹, Helber Gomes¹⁰, Dasa Gu¹¹, Alex Guenther^{1,11},
 5 Shantanu H. Jathar¹², Saewung Kim¹¹, Ying Liu¹, Sijia Lou¹, Scot T. Martin¹³, V. Faye McNeill¹⁴,
 6 Adan Medeiros¹⁵, Suzane S. de Sá¹³, John E. Shilling¹, Stephen R. Springston¹⁶, R.F. Souza¹⁷, Joel
 7 A. Thornton¹⁸, Gabriel Isaacman-VanWertz¹⁹, Lindsay Yee⁹, Rita Ynoue²⁰, Rahul A. Zaveri¹, Alla
 8 Zelenyuk¹, Chun Zhao^{1,21}

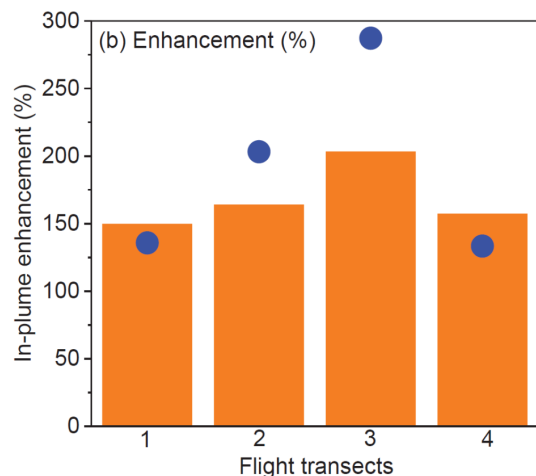
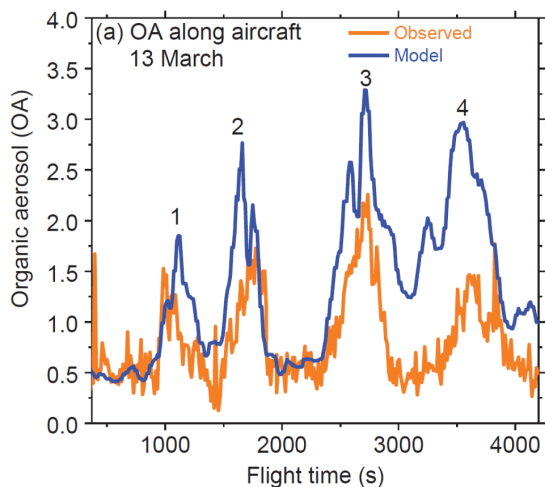
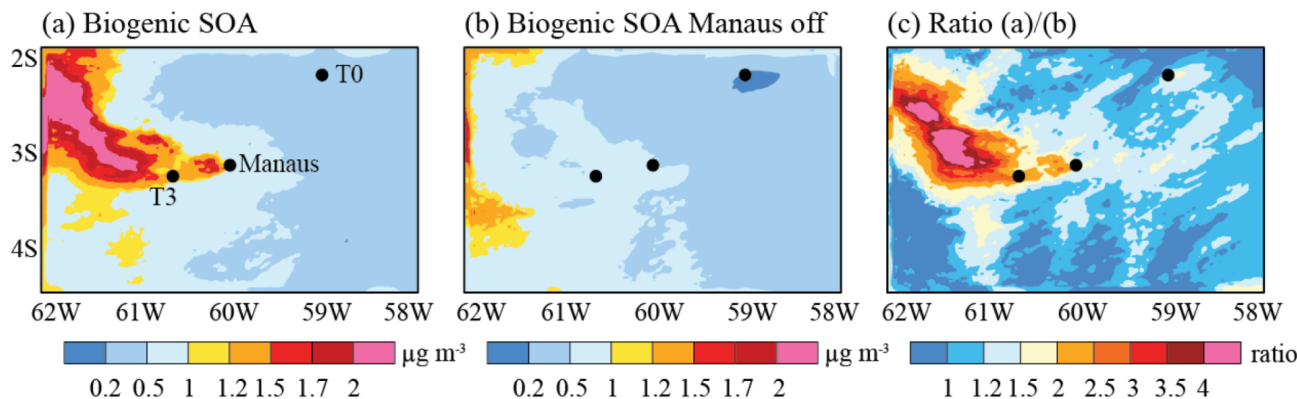

Fig.1. (a) OA measured along aircraft flight transects at 500-m altitude on March 13 (orange) and model-predicted OA, as described in the text. (b) Measured and model predicted average percent enhancement in plume compared to background organic aerosol on 4 different flight transects, as marked in (a). Bars represent measurements while symbols represent a model-predicted increase of OA within Manaus plume compared to background conditions



WRF-Chem simulations showing (a) Biogenic SOA when all emissions are on (b) Biogenic SOA when biogenic VOC emissions are on but Manaus emissions are turned off (c) Biogenic SOA enhancement factor calculated as the ratio of two simulations with Manaus emissions turned on/off i.e. (a)/(b). WRF-Chem predictions are at ~500 m altitude, averaged during the afternoon (16-20 UTC = 12-16 local time) of March 13, 2014.

2 Manish Shrivastava^{1,*}, Meimrat O. Andreae^{2,3}, Paulo Artaxo⁴, Henrique Barbosa⁴, Larry K. Berg¹,
 3 Joel Brito¹, Joseph Ching^{4,5}, Richard C. Easter¹, Jiwen Fan¹, Jerome D. Fast¹, Zhe Feng¹, Jose D.
 4 Fuentes⁷, Marianne Glasius⁸, Allen H. Goldstein⁹, Helber Gomes¹⁰, Dasu Gu¹¹, Alex Guenther^{12,13},
 5 Shantanu H. Jathar¹⁴, Sueuning Kim¹⁵, Ying Liu¹, Sijia Lou¹, Scot T. Martin¹⁶, Y. Faye McNeill¹⁴,
 6 Adnan Medeiros¹⁷, Suzane S. de Sá¹⁸, John E. Shilling¹, Stephen R. Springston¹⁹, R.F. Souza¹⁷, Joel
 7 A. Thornton⁴, Gabriel Isaacman-VanWertz¹⁹, Lindsay Yee⁹, Rita Ynoue²⁰, Rahul A. Zaveri¹, Alla
 8 Zelenyuk¹, Chun Zhao²¹

Fig. 3. WRF-Chem simulated concentrations of NO_x (ppbv), O₃ (ppbv) and OH (10⁶ molecule cm⁻³) for an altitude of ~500 m, averaged during the afternoon (16-20 UTC) of March 13, 2014. Top panels show simulations with all emissions on, while bottom panels show simulations with biogenic emissions on but Manaus emissions off. A comparison of top and bottom panels demonstrates how NO_x and oxidants are greatly enhanced by the Manaus plume within the otherwise pristine Amazon

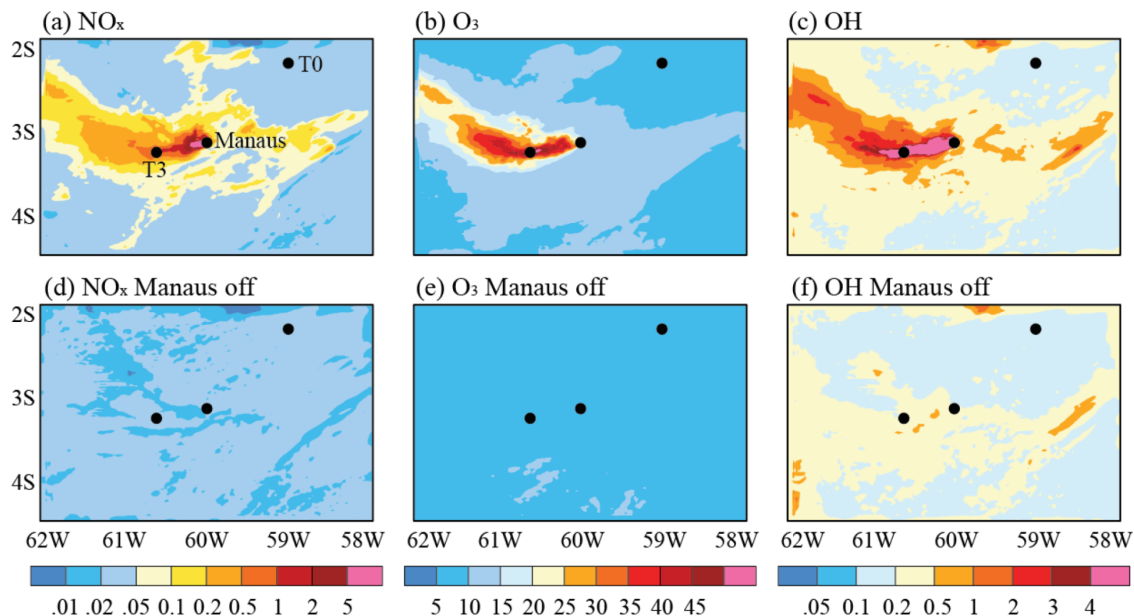

OA	Measured OA (µg m ⁻³)		Model OA (µg m ⁻³)		Percent Enhancement (Plume-Background)/Background*100	
	In-plume	Background	In-plume	Background	Measured	Model
Flight Transects March 13						
1	1.2	0.5	1.2	0.5	150	136
2	1.4	0.5	1.9	0.6	164	203
3	1.6	0.5	2.5	0.6	203	287
4	1.3	0.5	2.8	1.2	157	133
Flight March 14	1.6	0.9	2.1	1.2	80.2	76.5
Flight March 16	1.4	0.6	3.3	1.3	120.8	148.3

Aircraft-measured and WRF-Chem simulated median values of absolute OA concentrations in-plume and at background locations. Calculations are shown for individual flight transects on 13 March 2014, since the aircraft clearly identified the plume evolution on this day, as described in the text. An Average across all flight transects is shown for March 14 and 16, and the modeled plume was determined by scanning all radial locations downwind T1 site

How particles are produced in Amazonia?

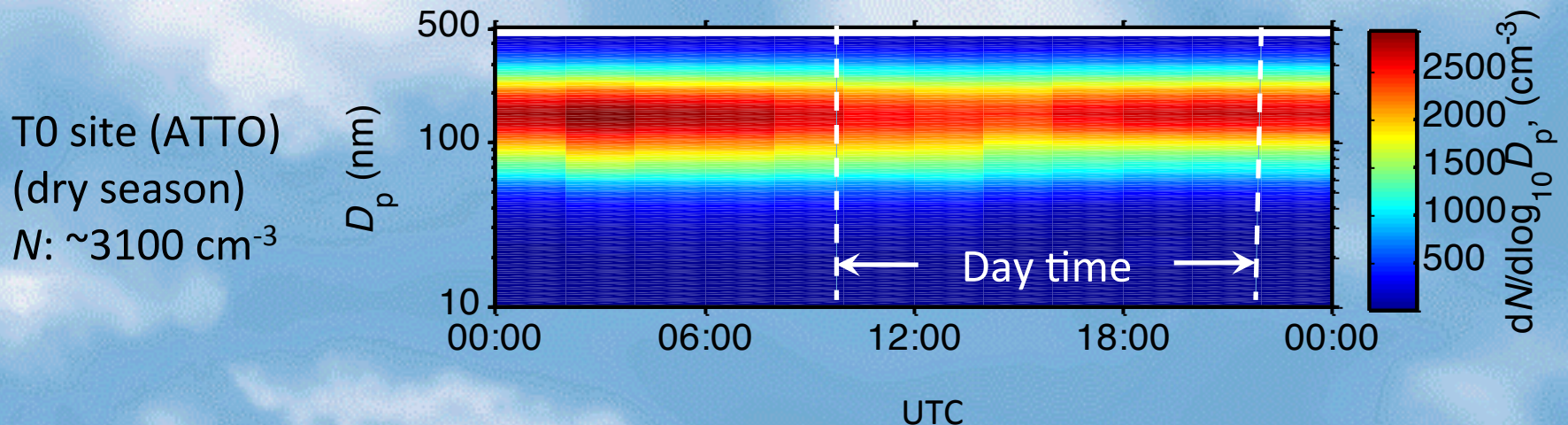
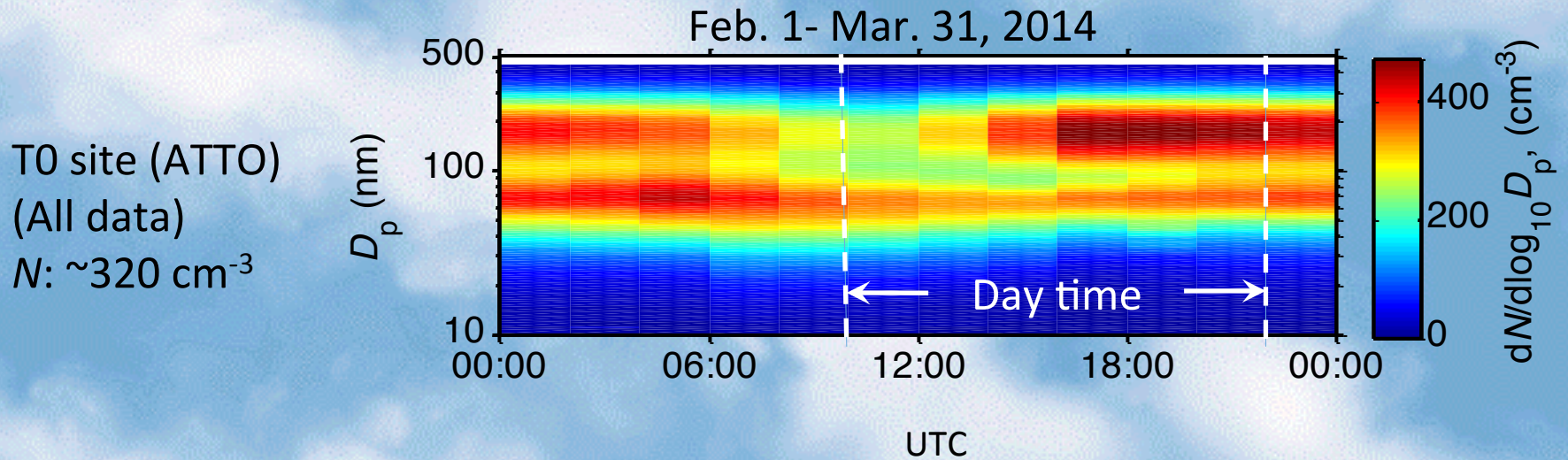

It rains a lot. Removal very high. How the particles are formed?

Central Questions

- What controls the lifecycle – especially the sources – of aerosols in the pristine atmosphere?
- How do secondary aerosol particles originate?
- What is the role of nucleation “banana” events?

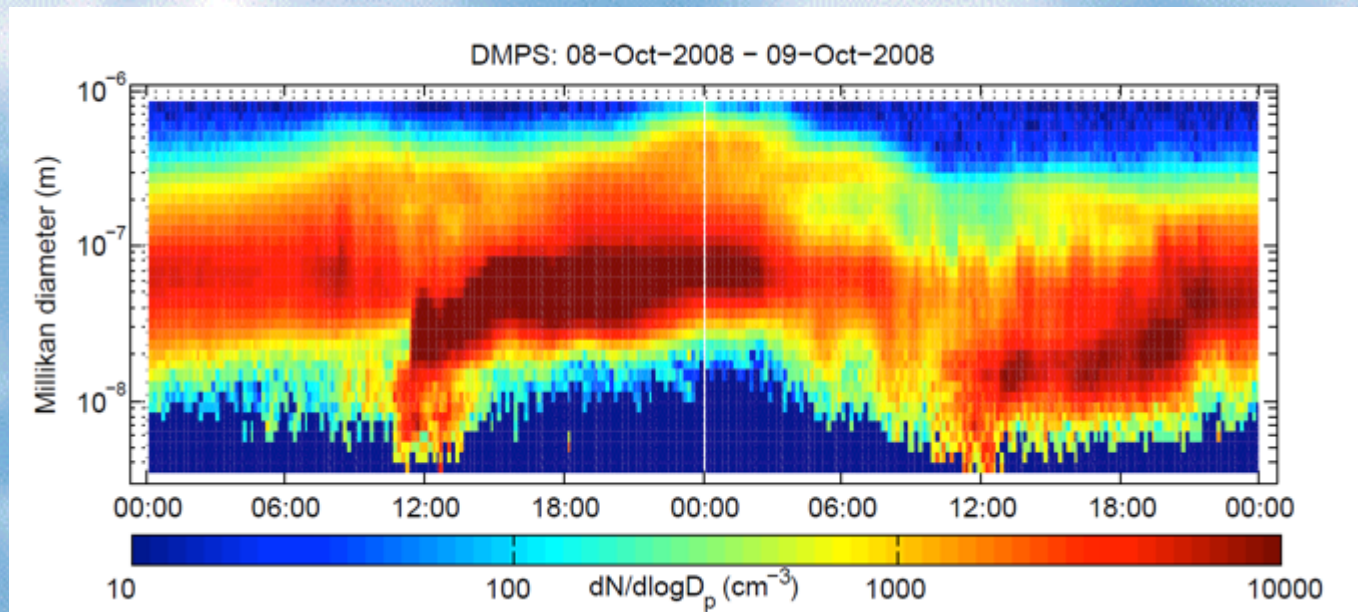

(Kerminen et al., 2012)

AMS Aerosol composition: Organics and nitrates. No sulfates

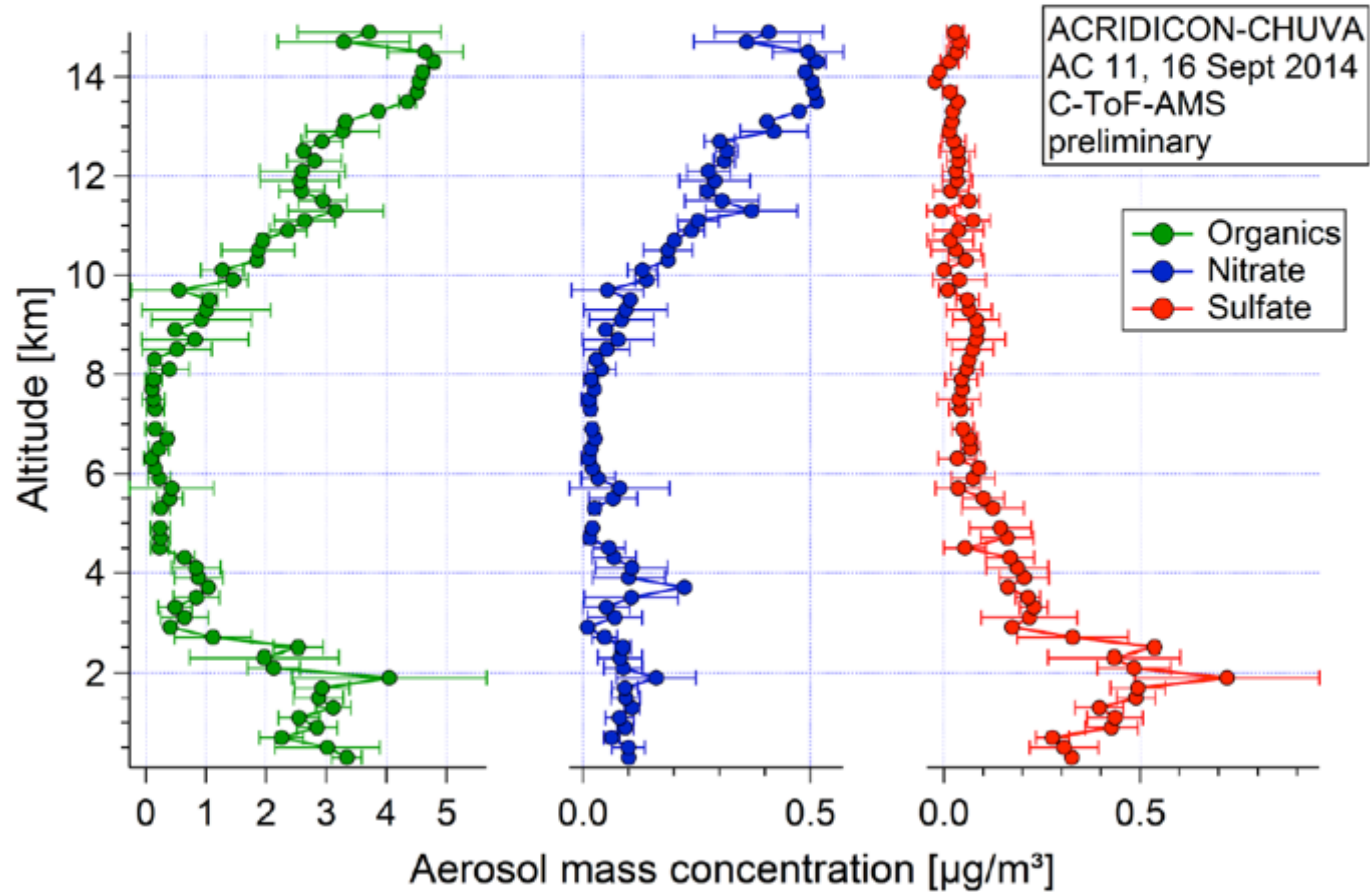

Andi Andreae, Schneider, in prep 2016



Aging of organic aerosol – AC 13 Altitude & f82 dependence

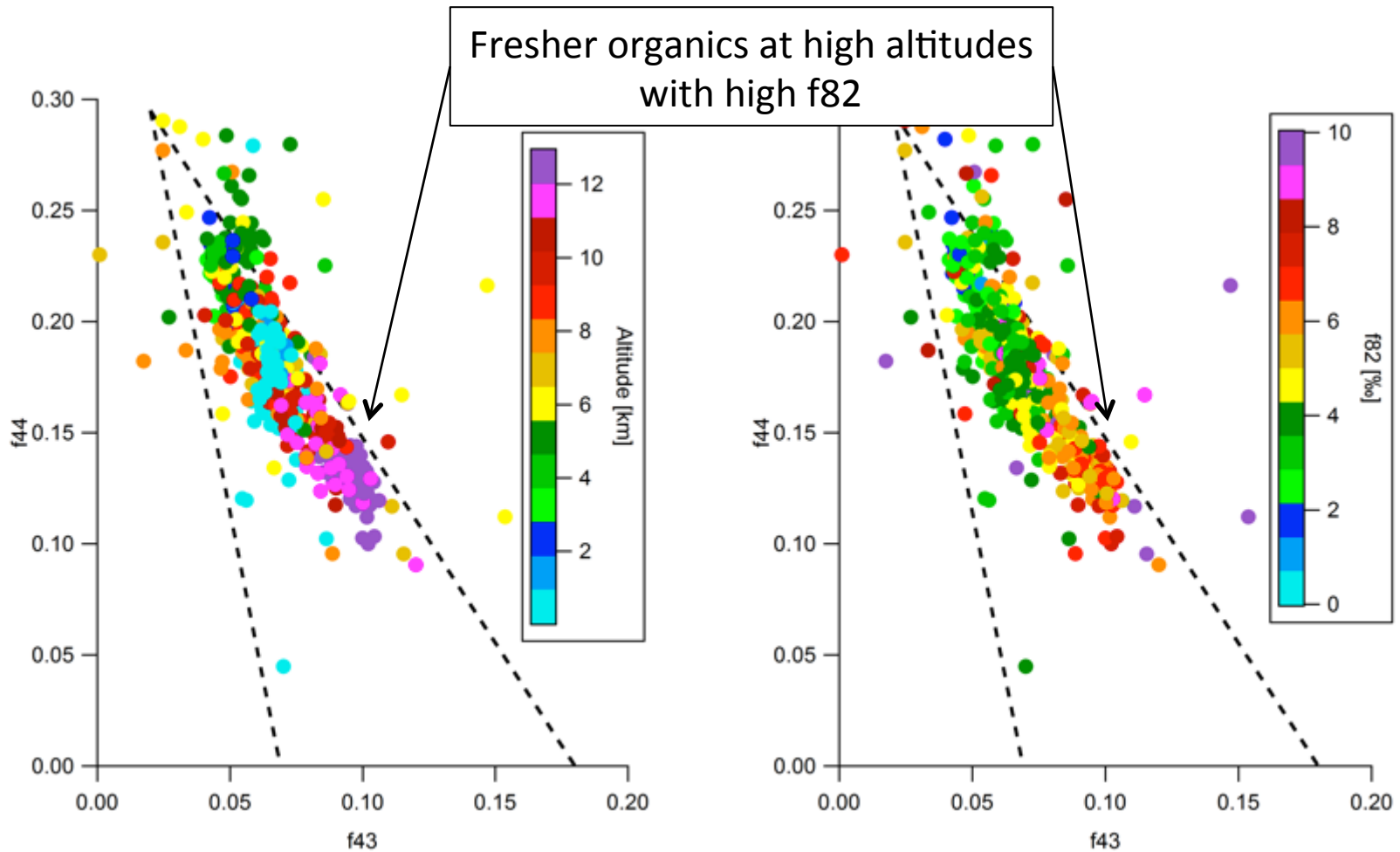

IEPOX tracer f82 against R44/43 for the lower troposphere (dark green, LT) and upper troposphere (light green, UT).

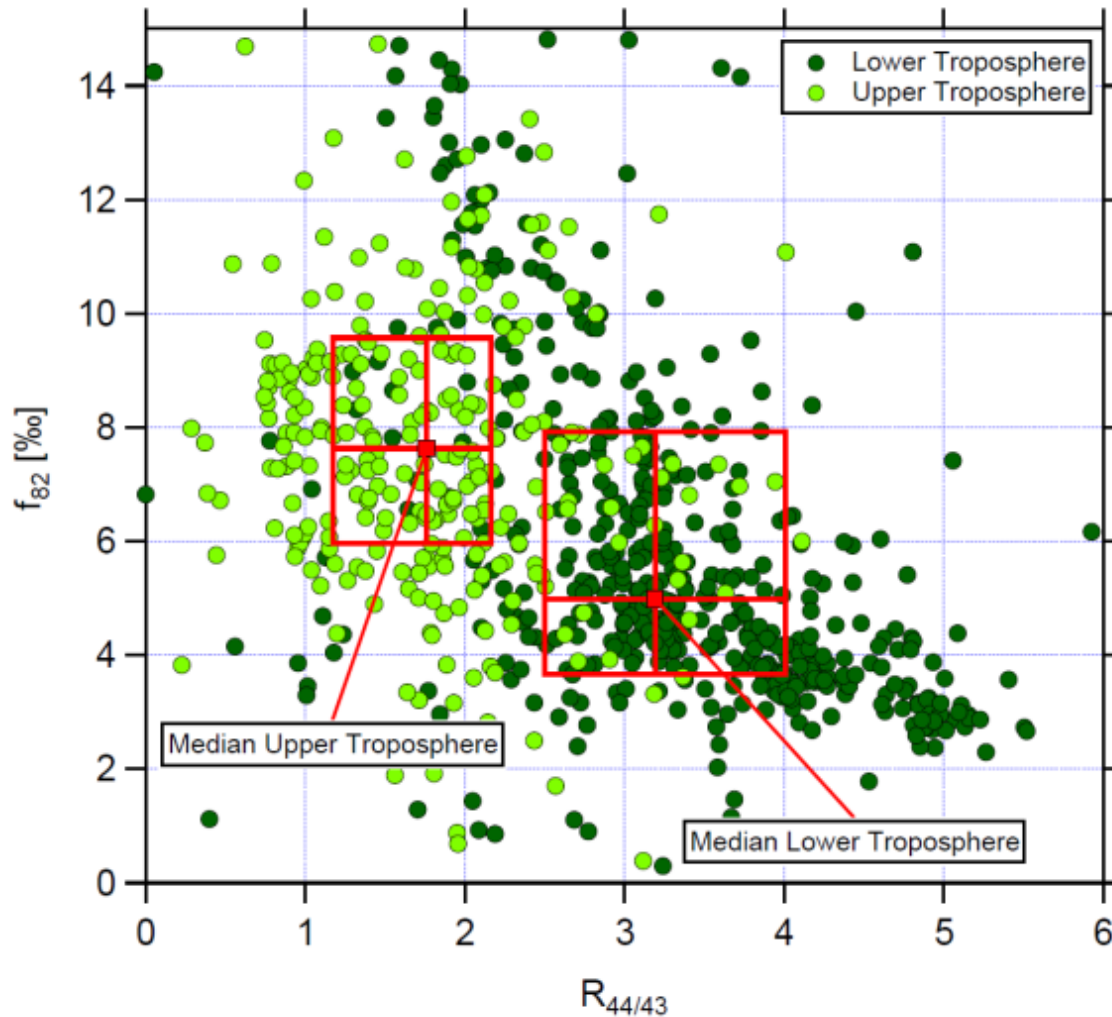

High altitude aerosols are fresh and mostly IEPOX derived...

Biogenic organic aerosol formation at low H_2SO_4 happens in UT!

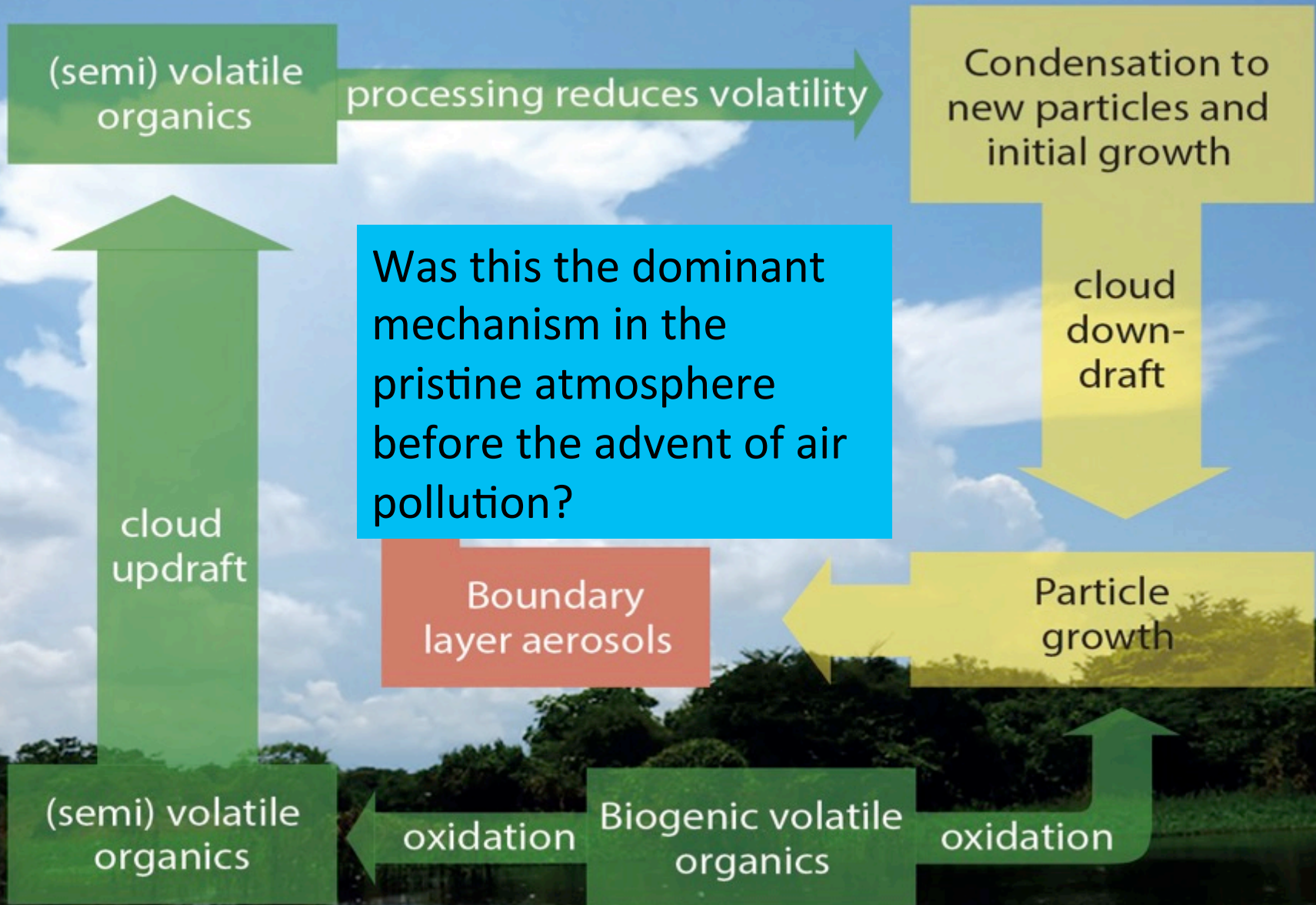

Clouds as active aerosol processors in the atmosphere

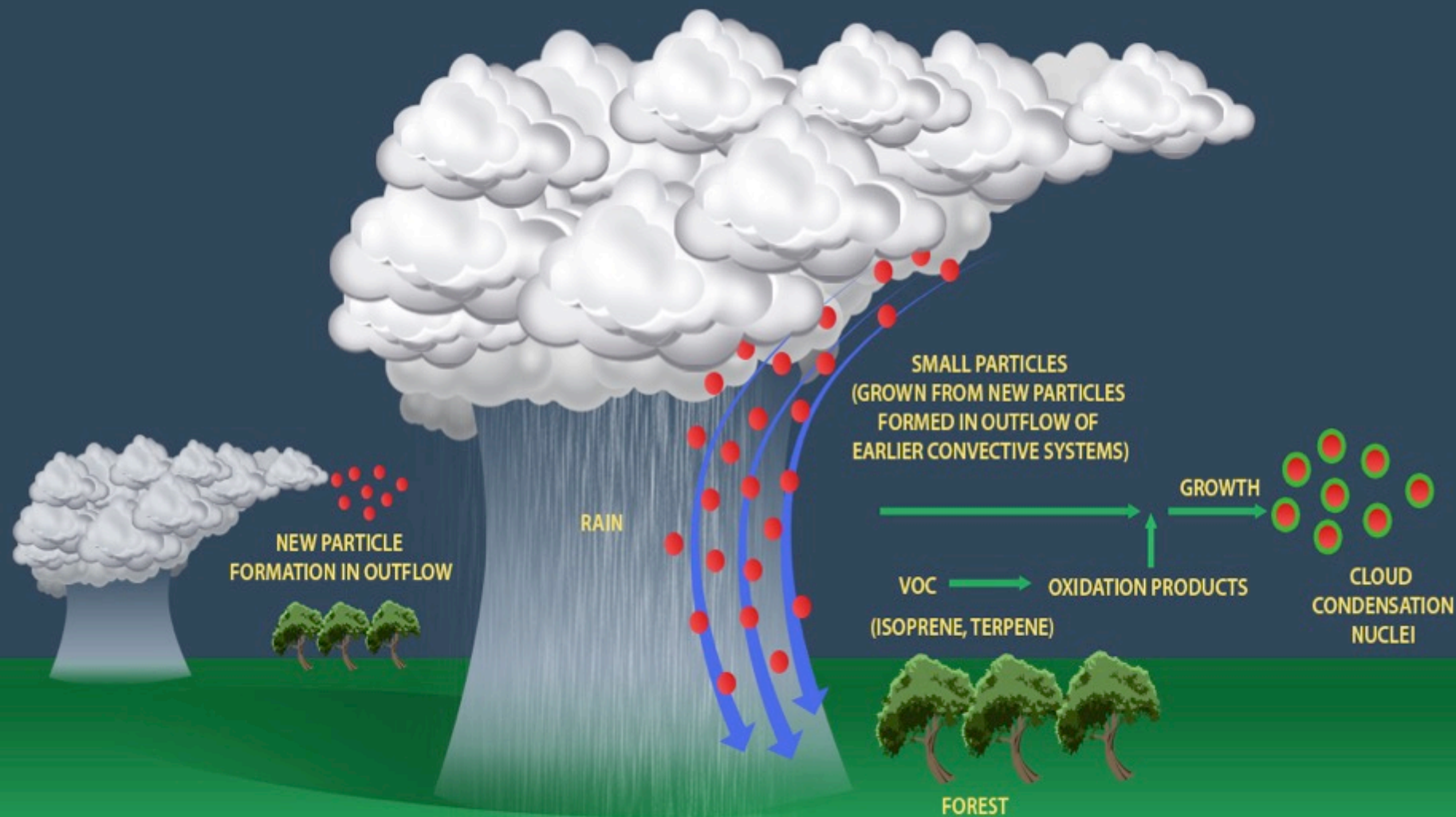

Convective precipitation brings these particles down to the surface

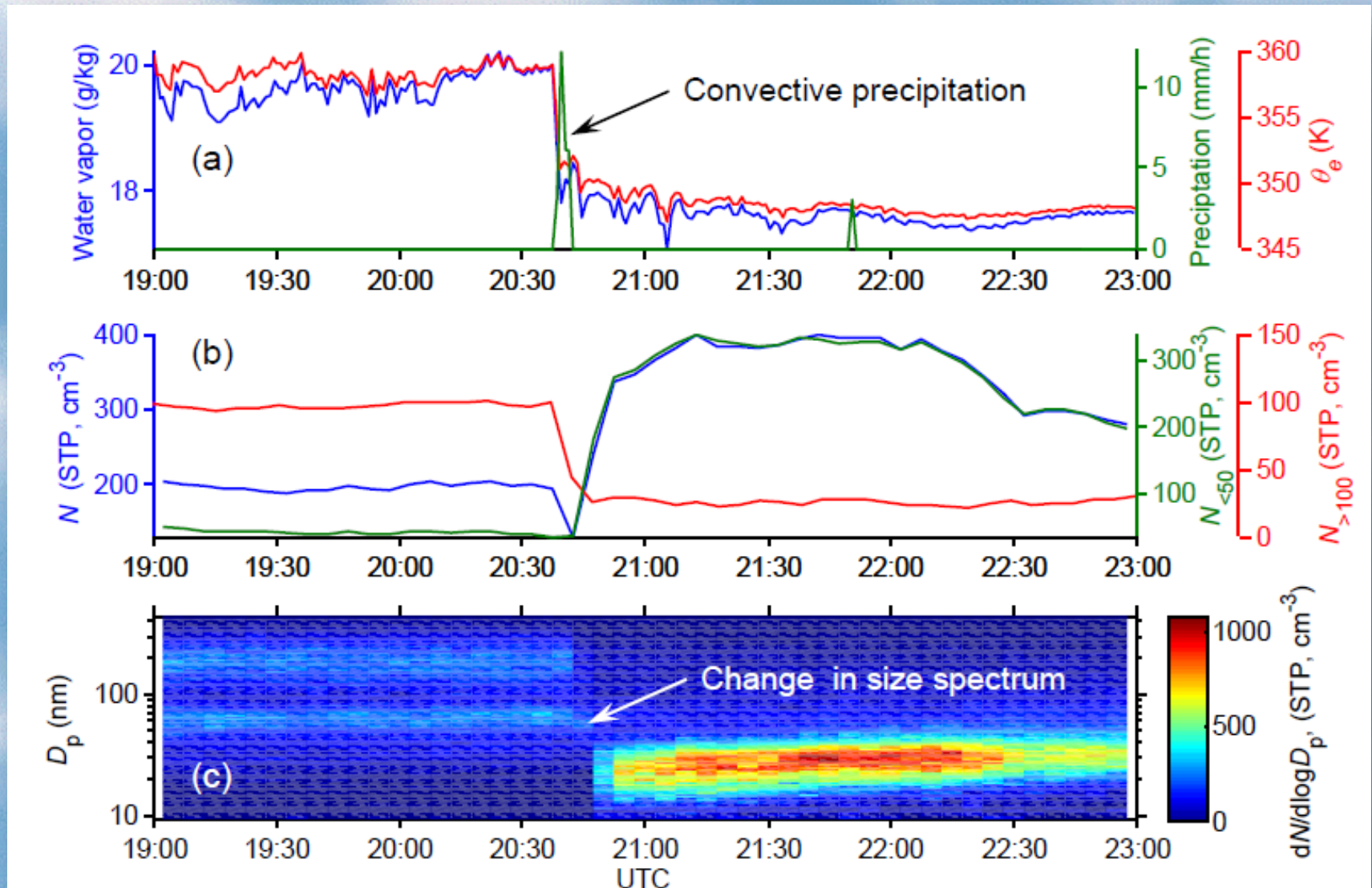



Thanks for the attention!!!!





Thanks for the attention!!

***Free data police: All GoAmazon data is freely available
at the DoE ARM site and in our Brazilian database***

Aerosol Hygroscopicity



Results: Dominated by organics, with very low hygroscopicity; Manaus plume affects the Aitken mode, oxidized T2->T3

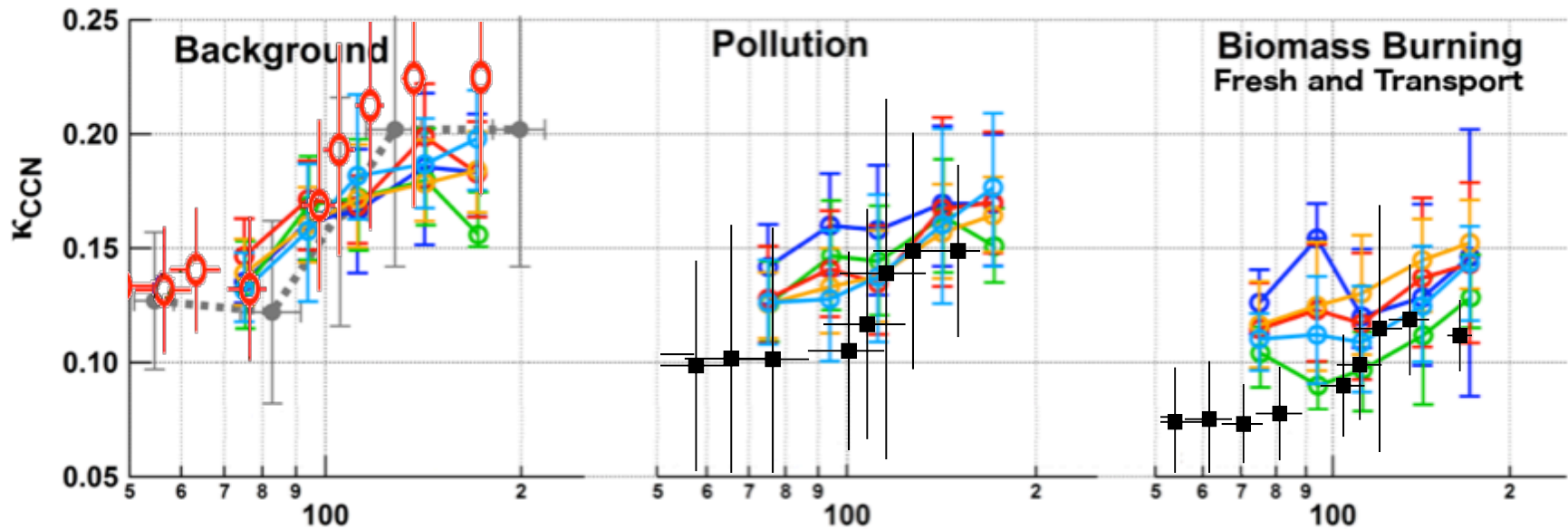

T3 ● Mar - May 2014 (Wet Season) ● Jun - July 2014 ● Aug - Oct 2014 (Dry season)
 ● Nov 2014 - Dec 2014 ● Dec 2014 - Mar 2015 (Wet season)
T2 ■
T0 ○

Isoprene Chemistry over the Amazon Rain Forest

Liu, Artaxo, Martin et al., PNAS

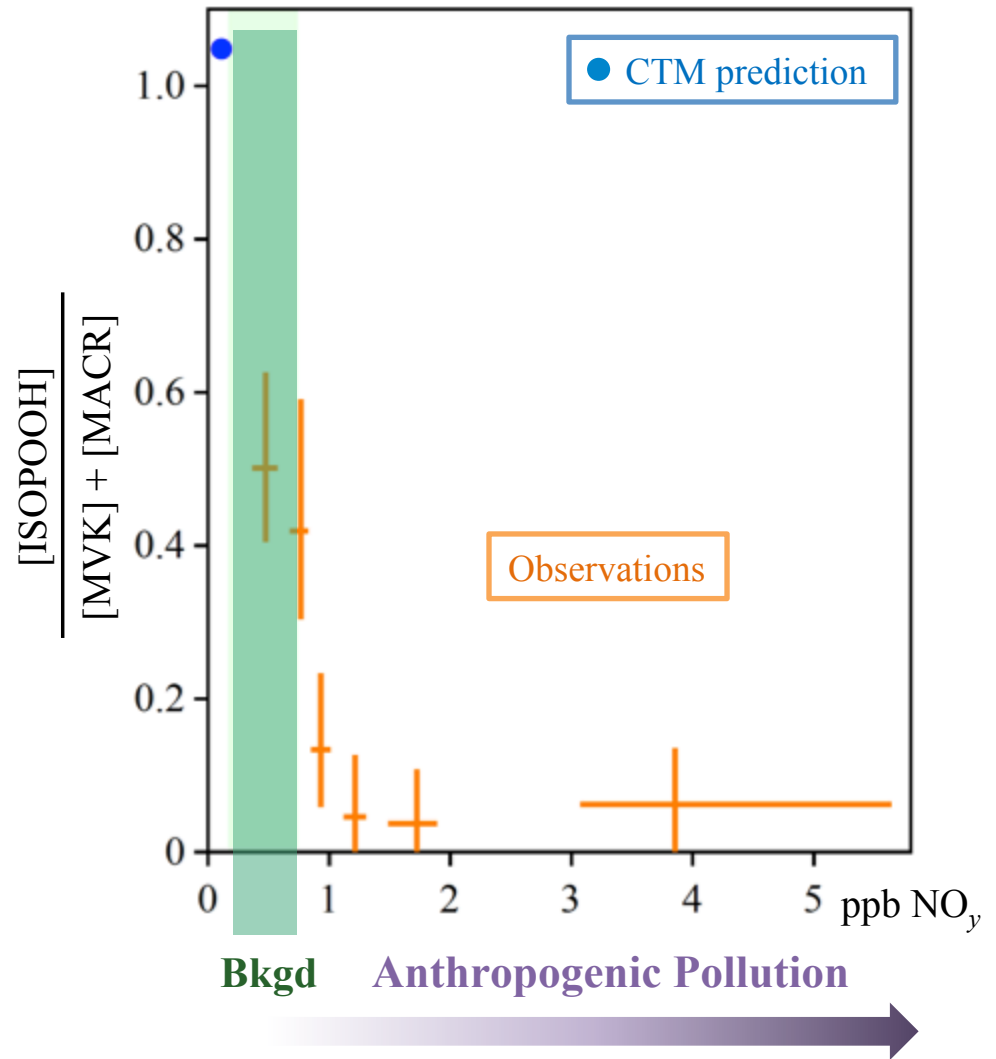
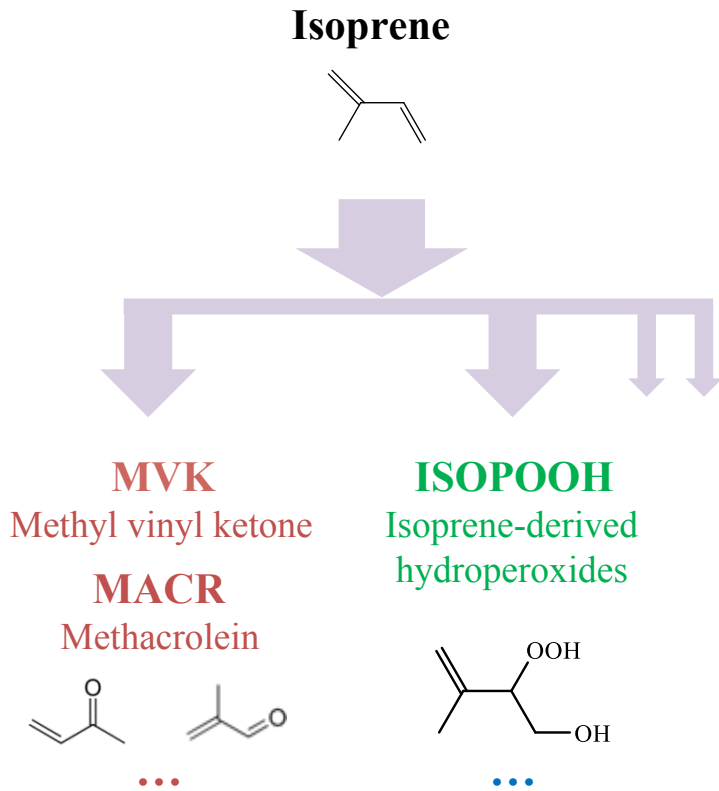

- Observational constraints of anthropogenic influence.
- Underestimate of the NO pathway for background conditions.



Aerossóis Carbonáceos

- Responsáveis por >70% da massa de aerossol na Amazônia;
- Diferentes tipos de aerossóis carbonáceos:
 - Carbono orgânico (OC):
 - refere-se ao carbono presente em compostos majoritariamente orgânicos;
 - pode ser primário ou secundário (SOA);
 - Carbono elementar (EC):
 - Fração de carbono com composição similar à fuligem;
 - Altamente absorvedor de radiação;
 - Black Carbon (BCe):
 - Carbono altamente absorvedor de luz com propriedades ópticas semelhantes às da fuligem.

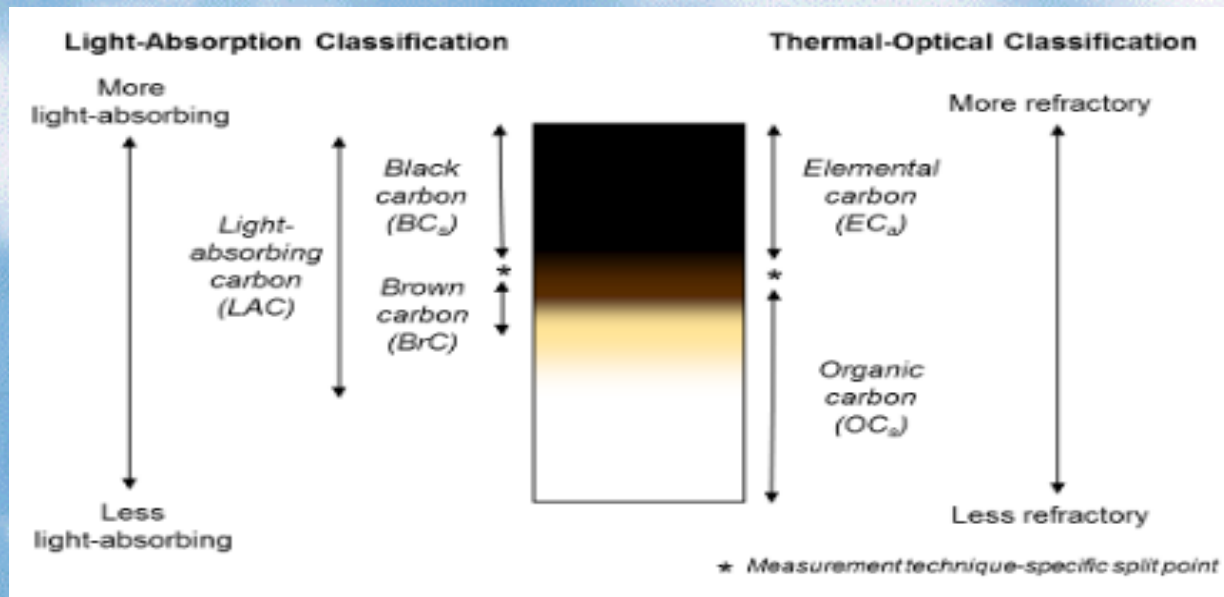

Isoprene Photochemistry in Transition?

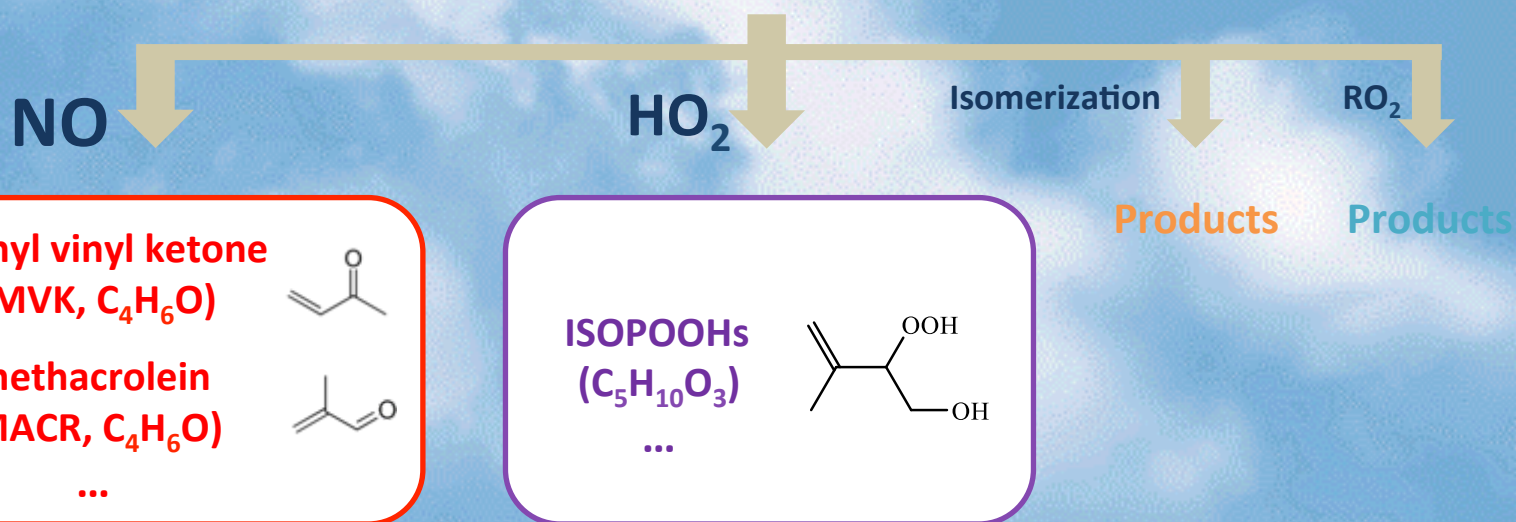
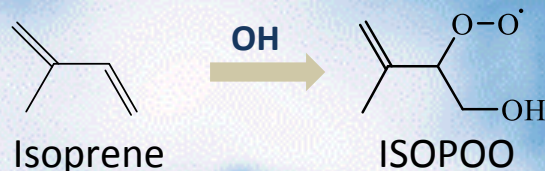

(Tuazon et al., 1990; Paulot et al., 2009; Surratt et al., 2010; Crouse et al., 2011, Peeters et al., 2009; 2010; 2014; Fuchs et al., 2013...)

Amazonia: Liquid Organic Particulate Matter

Aerosols are part of the liquid atmosphere (not the solid one)...

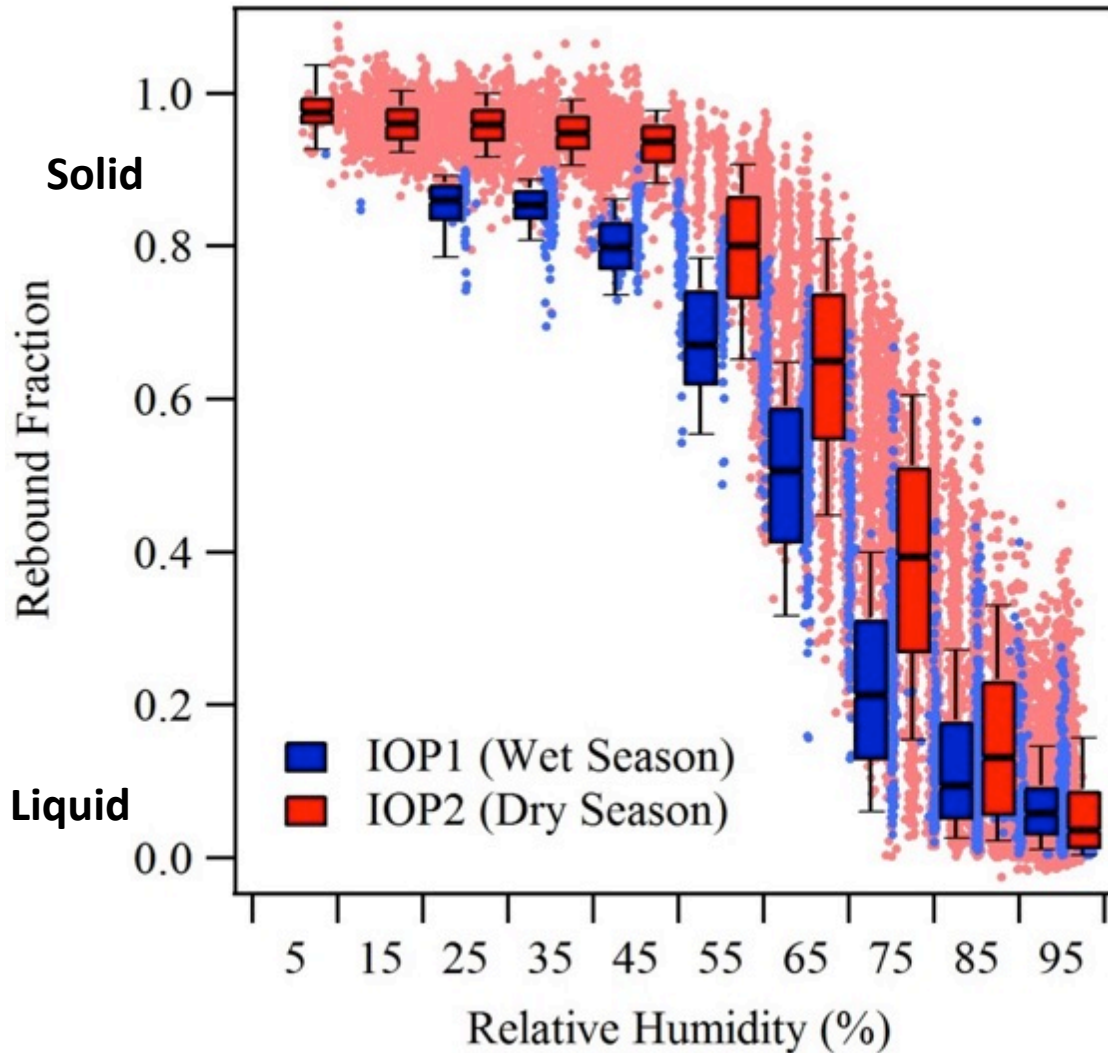

Adam P. Bateman¹, Zhaoheng Gong¹, Pengfei Liu¹, Bruno Sato², Glauber Cirino³, Yue Zhang¹, Paulo Artaxo⁴, Allan K. Bertram⁵, Antonio O. Manzi³, Luciana V. Rizzo⁶, Rodrigo A. F. Souza⁷, Rahul A. Zaveri⁸ and Scot T. Martin^{1,9*}

Sub-micrometre particulate matter is primarily in liquid form over Amazon rainforest

How external (Biomass Burning, Sahara dust, pollution) and internal emissions (primary organic aerosol particles and SOA) interact chemically and physically altering aerosol and cloud properties.

2 years continuous measurements at seven ground based stations and two aircraft flying dry and wet seasons

Pöschl, et al., *Science*, 2010

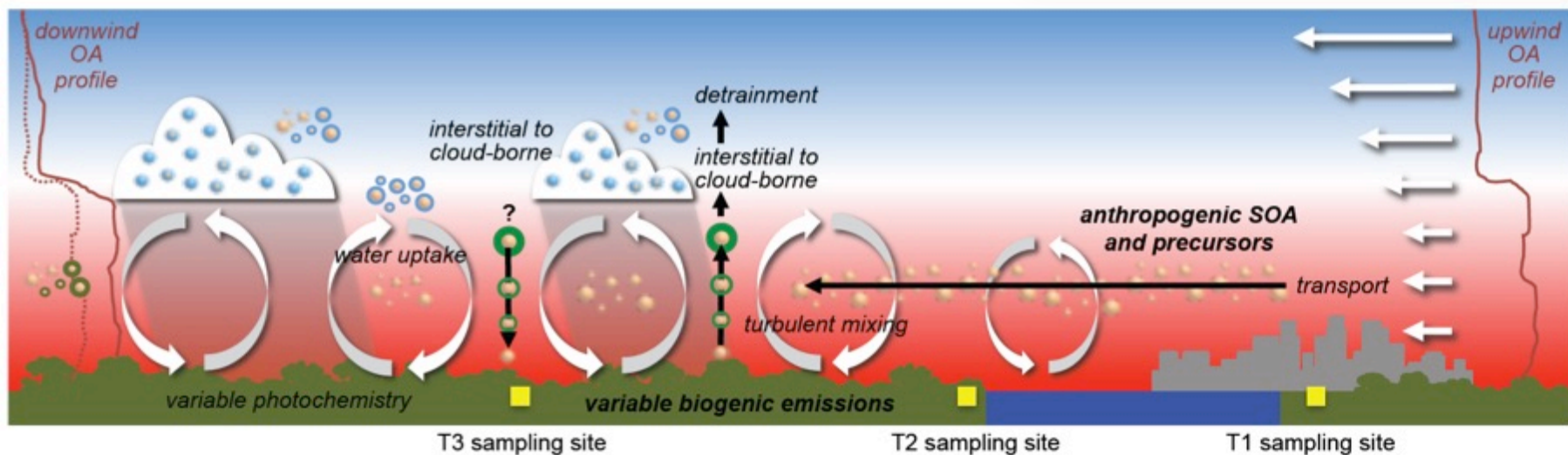
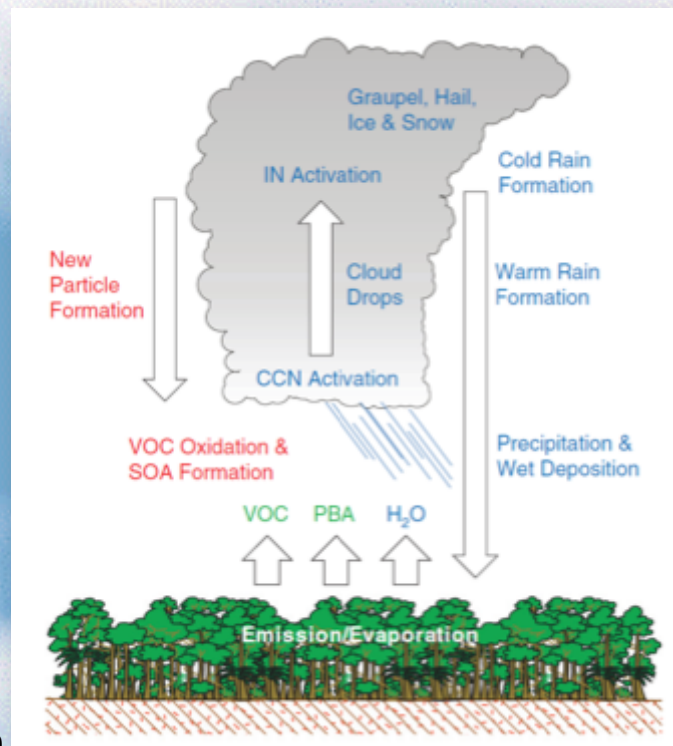

Image Source: Jerome Fast

T0z: Scattering versus organics

